

# LZ & XLZD

Liverpool Group

Sean Hughes

May 2026



# LZ & XLZD Liverpool Group

## PhD Students:

- ❑ Brandon Crowley
  - ❑ Neutron studies with silicon sensors
- ❑ Bethan Twigg
  - ❑ LTA - Planned for Zurich
  - ❑ Demonstrator LXe detectors
- ❑ Tea Hall
  - ❑ On LTA in University of Texas at Austin
  - ❑ CrystaLiZe, Solid Xe TPC
- ❑ Megan Carter
  - ❑ High energy nuclear recoils
  - ❑ Effective Field Theory

## PDRAs:

- ❑ Sean Hughes - XLZD
  - ❑ Began XLZD Geant4 framework, now XLZD Geant4 Simulations co-convenor
  - ❑ Prototyping
- ❑ Ewan Fraser - LZ
  - ❑ Data Quality Coordinator

## Engineering:

- ❑ James Coleman-Mills
- ❑ Balint Bogdan

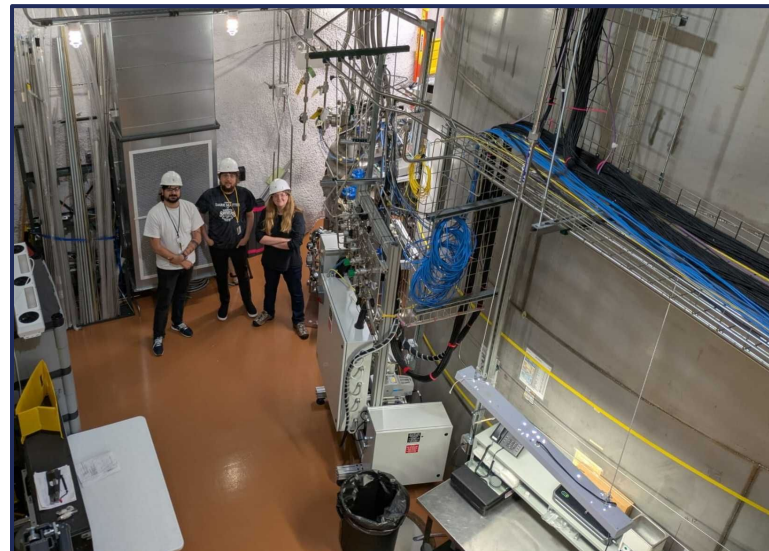

Prof. Sergey Burdin

# Dark Matter Search with LXe TPC

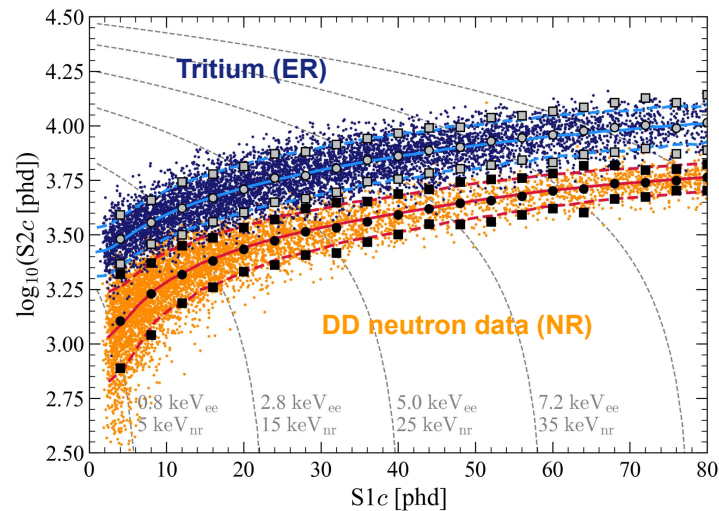
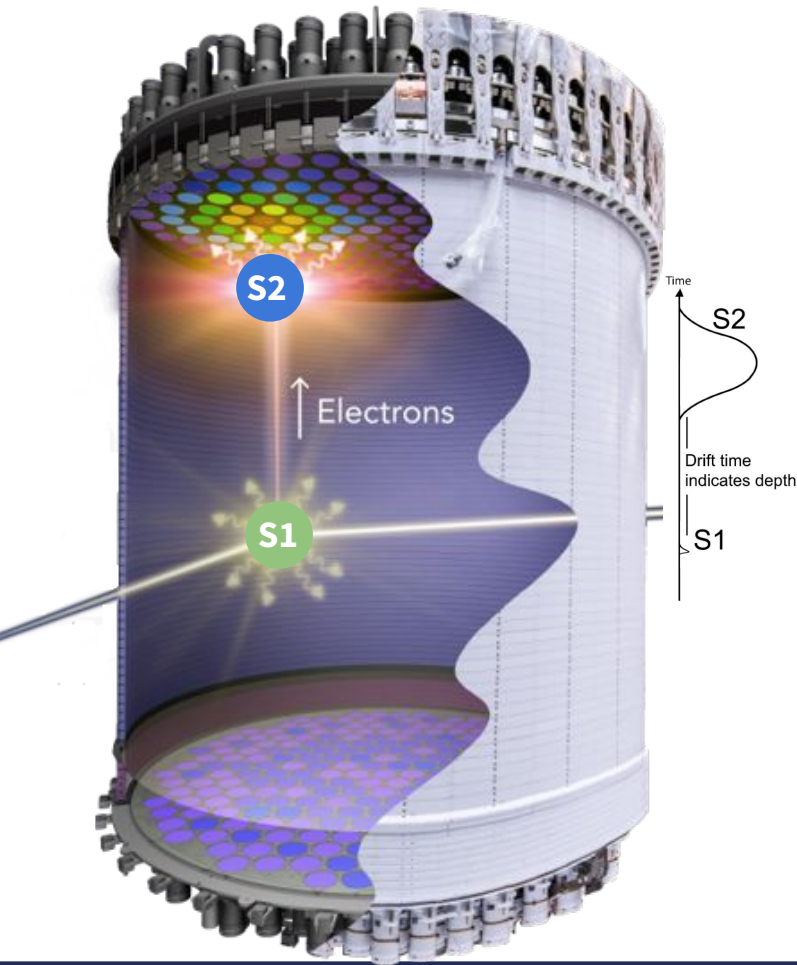

2024 Electronic Recoil (ER) and Nuclear Recoil (NR) discrimination in calibration

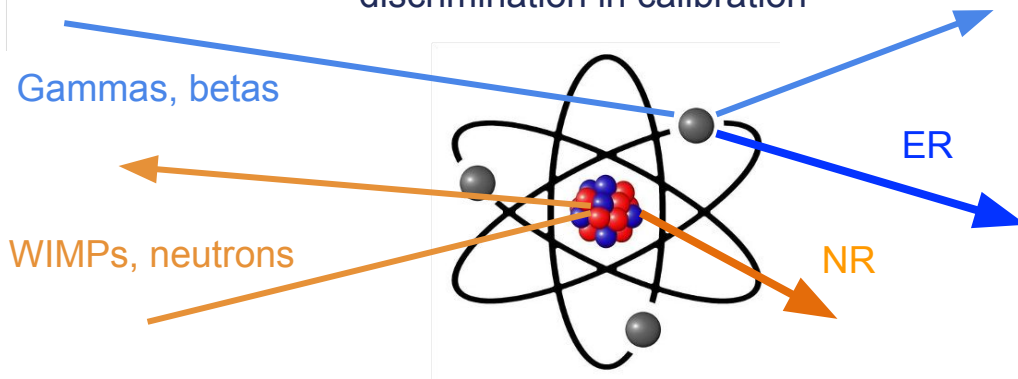

# WIMP Search 2024 Results

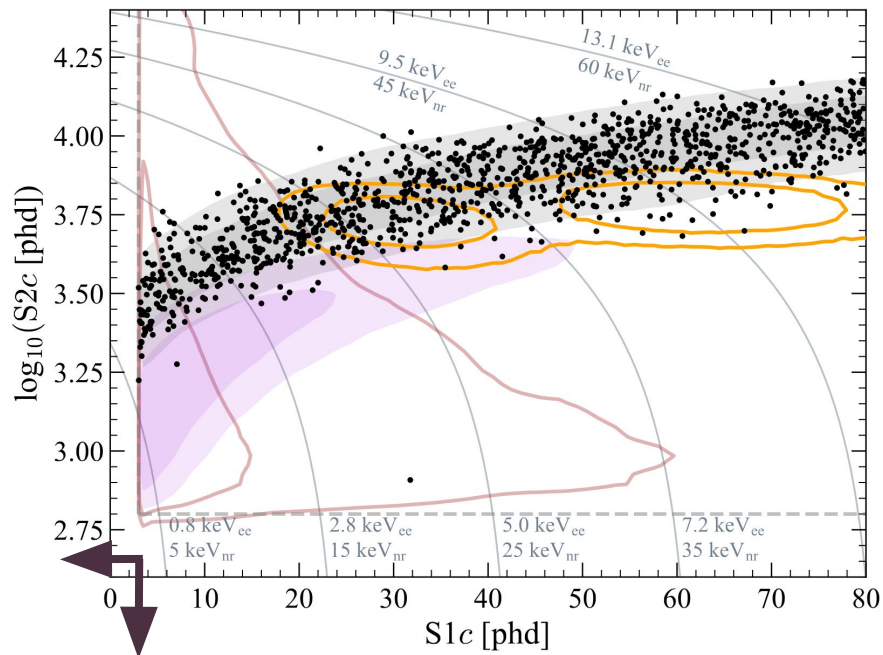

- ❑ Final exposure: 280 live days
- ❑ Consistent with a background only hypothesis
- ❑ World leading limit  $\sigma_{SI} = 2.1 \times 10^{-48} \text{cm}^2$  for 36  $\text{GeV}/c^2$

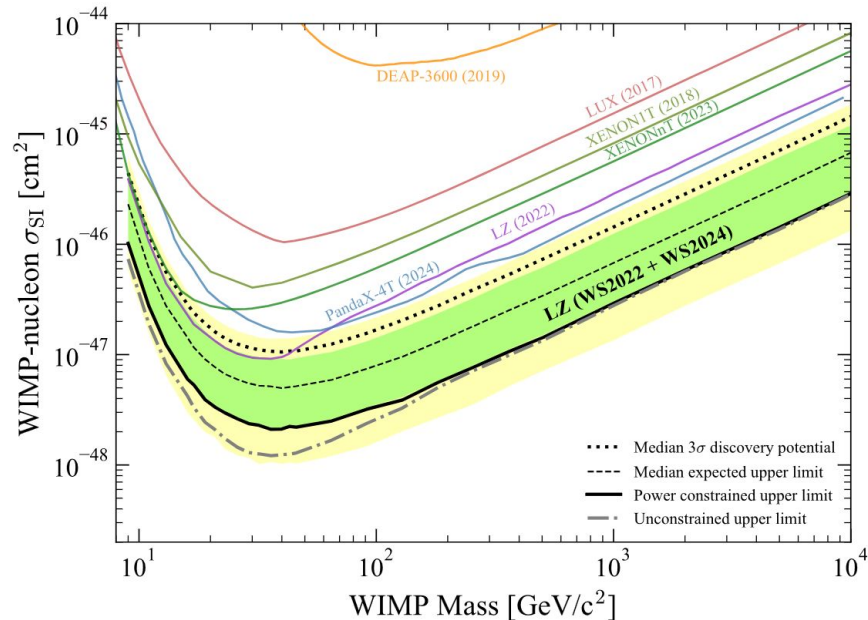

- ➔ To lower WIMP masses!
- ❑ Increased instrumental background
- ❑ CE $\nu$ NS from  $^8\text{B}$  solar neutrinos

# Low Mass WIMP search: Data Quality

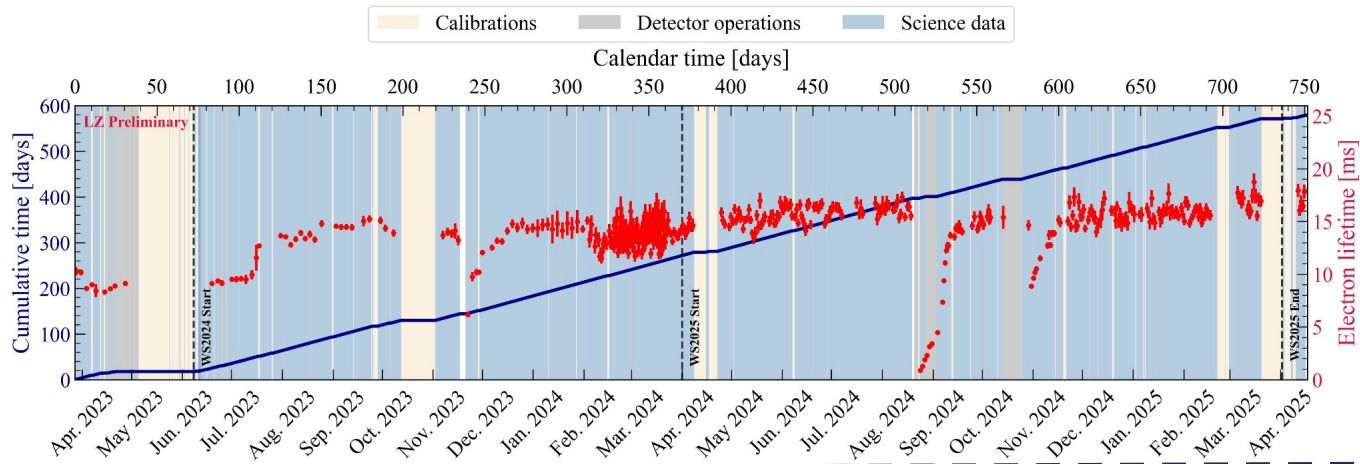

WIMP Search 2025 [\[1\]](#)

417 live day exposure

5 tonne LXe volume

## Instrumental Background: Accidentals

Coincidence of uncorrelated isolated S1s and isolated S2s

- ❑ Background: Physical Drift time accidentals
- ❑ Side-band: Unphysical Drift time accidentals

Isolated S1s:

- ❑ Scatters in charge insensitive regions
- ❑ Pile-up of fluorescence photons

Isolated S2s:

- ❑ Small energy depositions
- ❑ Pile-up of (photoionisation) electrons

## Accidental Single Scatters

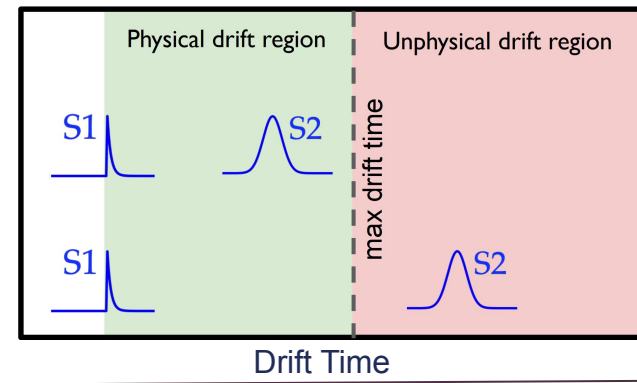

# Low Mass WIMP search: Data Quality

## Fluorescence following Large S2s

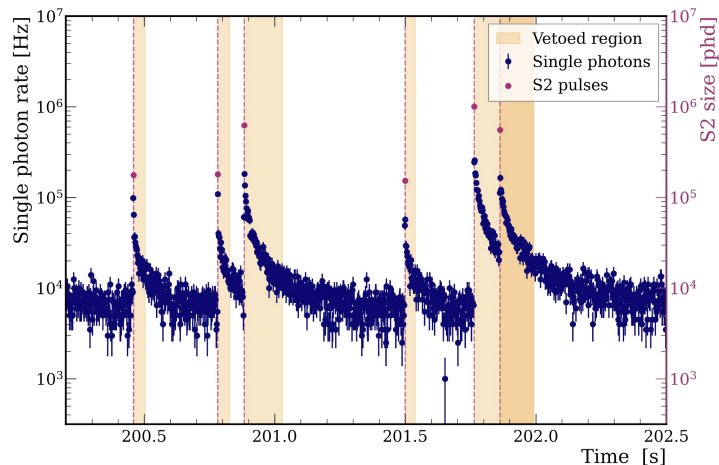

- ❑ PMT Quartz & PTFE fluorescence [\[2\]](#)
- ❑ Veto periods following large S2s
  - ❑ Minimise isolated S1s
- ❑ Also produces photoionisation electrons
  - ❑ Minimise isolated S2s [\[3\]](#)
- ❑ Minimise accidentals
- ❑ Corresponds to a ~16% exposure loss

## Grid Emission Veto - 417 livedays

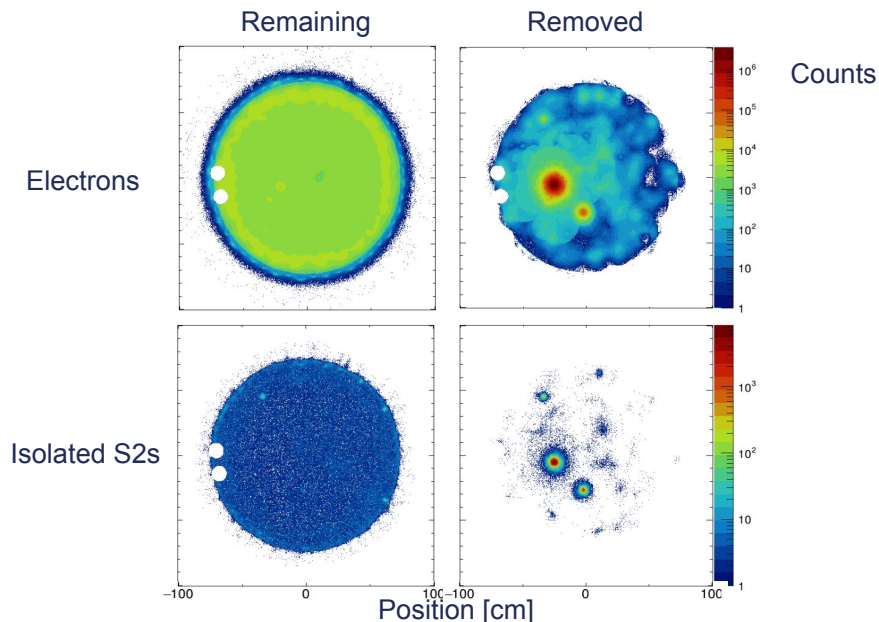

- ❑ Cathode, Gate, Anode - Spontaneous electron emission
  - ❑ Can be transient or sustained
- ❑ Computer vision analysis of per day electron maps
  - ❑ Identify grid emission
- ❑ ~40% background reduction, ~1.5% Exposure loss

# Low Mass WIMP search: CENs from $^8\text{B}$ solar neutrinos

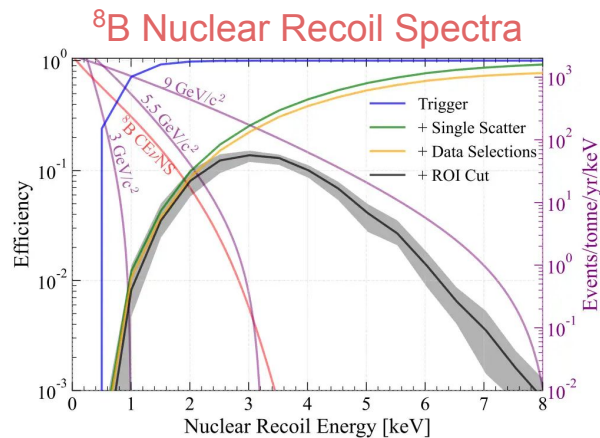
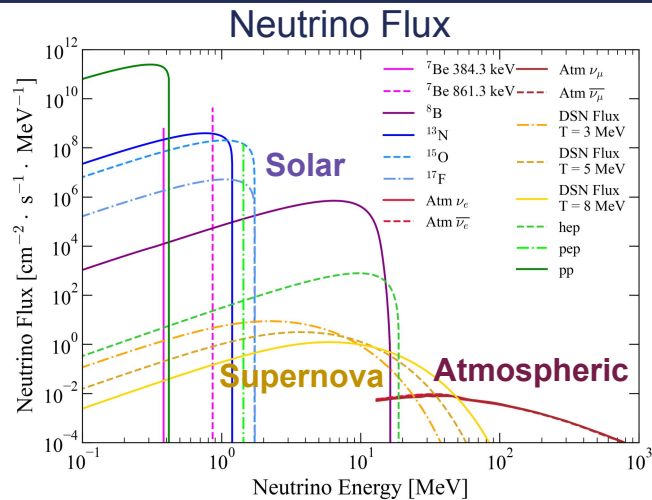

Coherent elastic neutrino nucleus scattering

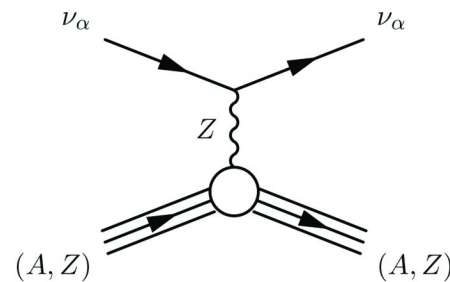

Neutrino Fog

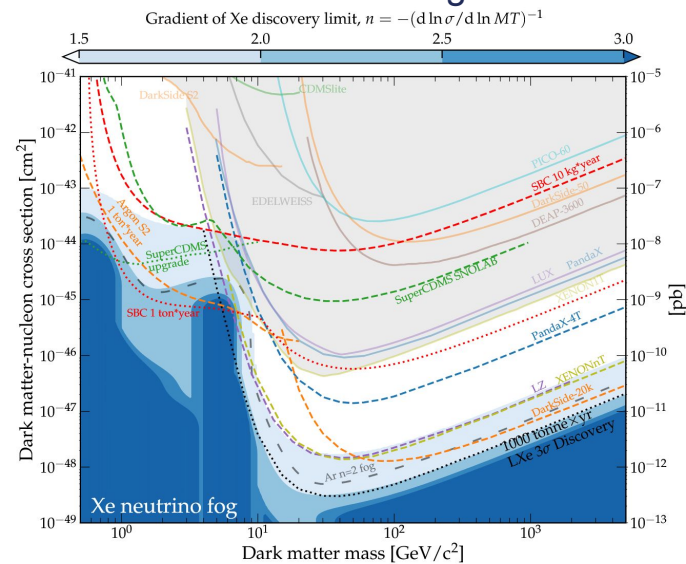

# Low Mass WIMP search: Results

## 3 GeV/c<sup>2</sup> WIMP search

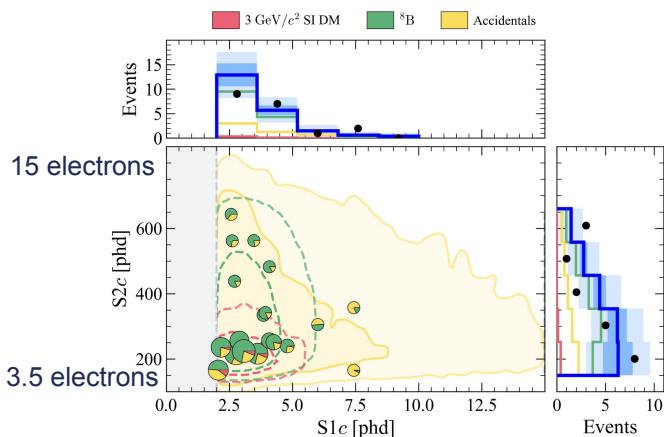

## WIMP-nucleon spin independent limit

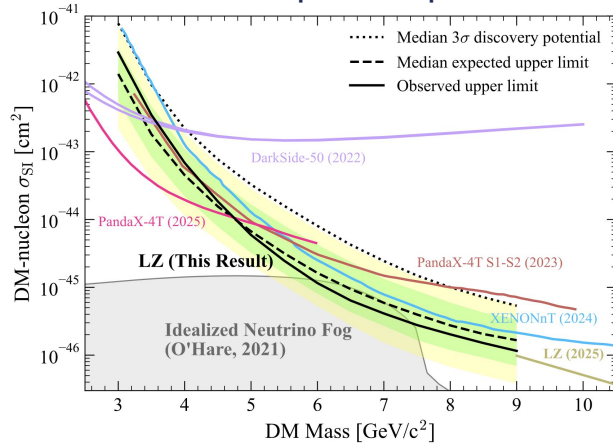

- ❑ WIMP search consistent with the background only hypothesis
  - ❑ For masses tested: 3-9 GeV/c<sup>2</sup>
  - ❑ World leading limits placed [4]
- ❑ Well constrained accidentals background
- ❑ Evidence for discovery of LXe <sup>8</sup>B CE $\nu$ NS
  - ❑ 4.5 $\sigma$  significance
  - ❑ Consistent <sup>8</sup>B flux and weak-mixing angle ( $\sin^2\theta_W$ )

## <sup>8</sup>B CE $\nu$ NS Evidence

Components	Expectation	Fit Results
<sup>8</sup> B CE $\nu$ NS	-	12.3 <sup>+7.0</sup> <sub>-5.4</sub>
Accidental coincidences	6.6 ± 0.3	6.6 ± 0.3
Detector neutrons	0.04 <sup>+0.25</sup> <sub>-0.04</sub>	0.1 <sup>+0.2</sup> <sub>-0.1</sub>
Total	6.6 ± 0.3	18.9 <sup>+7.0</sup> <sub>-5.5</sub>

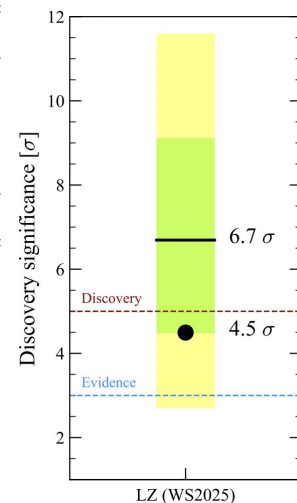
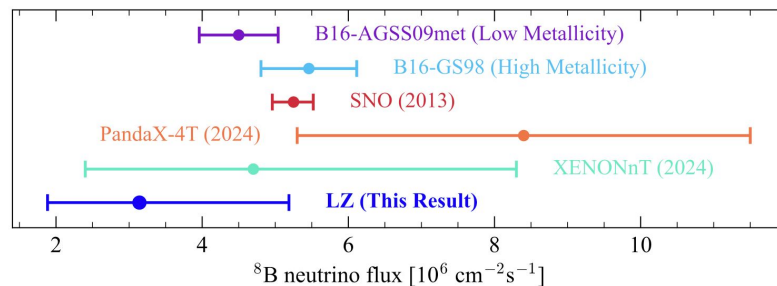

# XLZD & CDR Preparation

- The next generation Liquid Xenon Observatory for Dark Matter Physics

- [XLZD White Paper](#)
- [Design book](#)

- September 2024, **XLZD** Collaboration formed

- **XENONnT, LUX-ZEPLIN, DARWIN**

- Nominally feature a dual phase LXe TPC with 1:1 aspect ratio => 60 tonnes

- Upgrade to 80 tonnes

- Preconstruction initiatives ongoing - **CDR EOY 2026!**

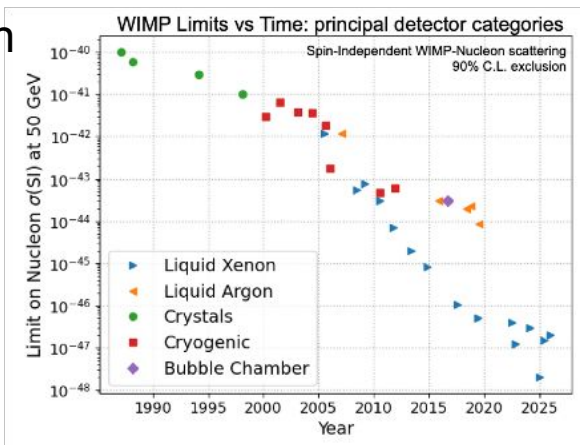

'French Press'  
TPC design



**Dark Matter**  
WIMPs  
Sub-GeV  
Inelastic  
Axion-like particles  
Planck mass  
Dark photons

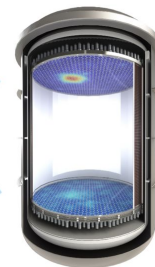
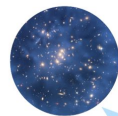

**Neutrino nature**  
Neutrinoless double  
beta decay  
Neutrino magnetic  
moment  
Double electron  
capture

**Supernovae**  
Early alert  
Supernova neutrinos  
Multi-messenger  
astrophysics

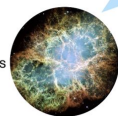

**Sun**  
pp neutrinos  
Solar metallicity  
 ${}^7\text{Be}$ ,  ${}^8\text{B}$ , hep

# XLZD Physics

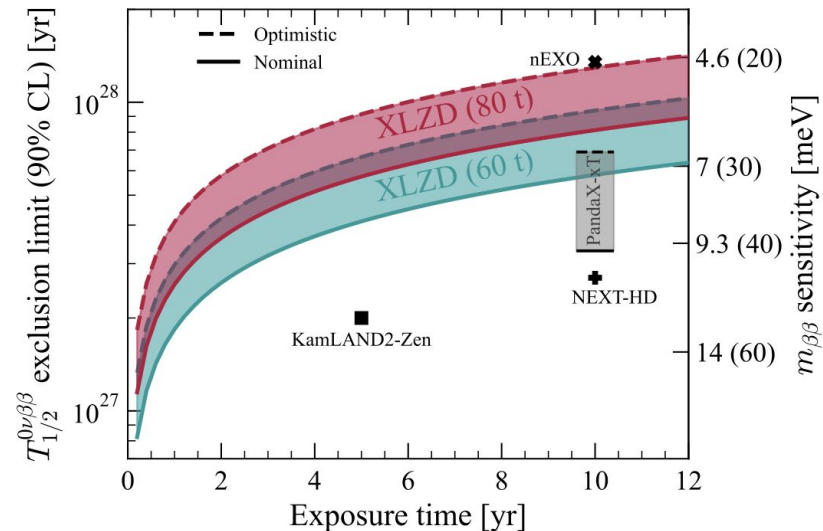
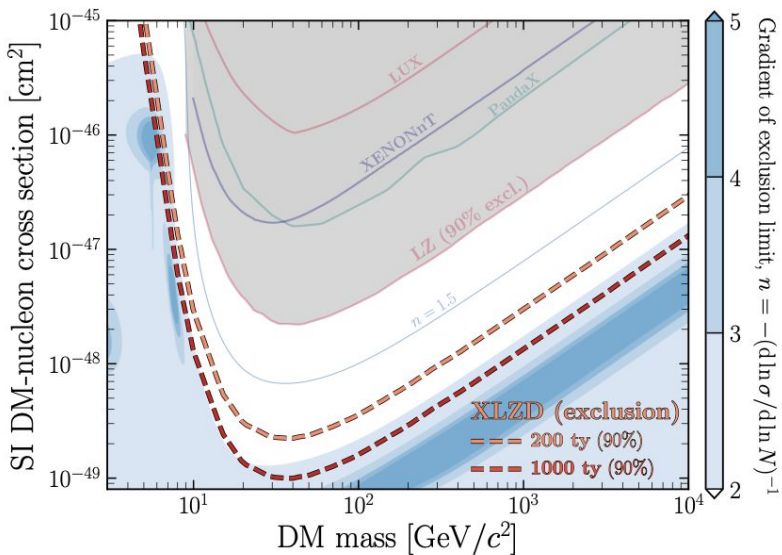

Current technology will likely be unsuitable once the neutrino fog has been reached  
=> motivation towards achieving best possible sensitivity with XLZD!

Competitive sensitivity to neutrinoless double beta decay using natural xenon

# XLZD Siting

Five sites have expressed interest in hosting XLZD

Site selection ongoing, setting requirements such that underground facilities reach XLZD science goals

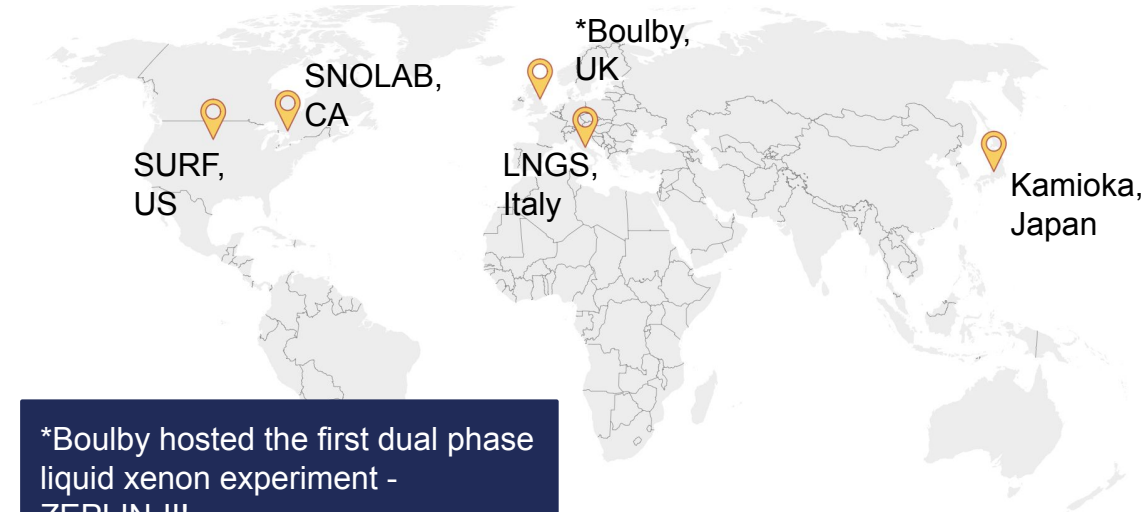

\*Boulby hosted the first dual phase liquid xenon experiment - ZEPLIN-II!

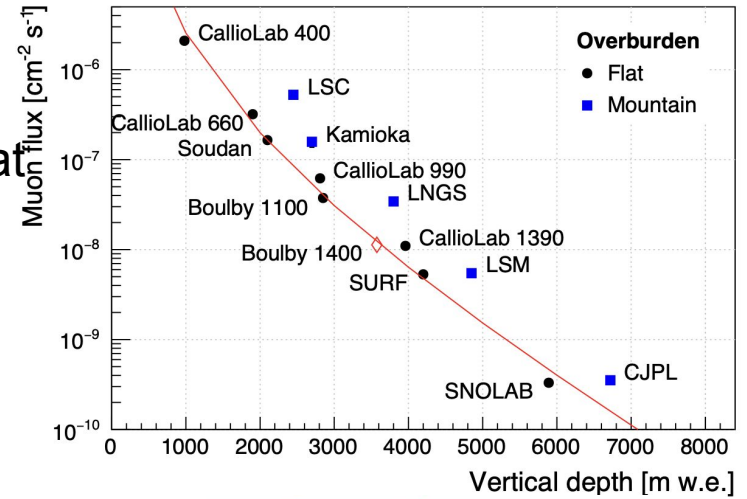

# XLZD@Boulby preconstruction initiative

- University of Liverpool is a member of the XLZD@Boulby preconstruction project
- Leading the development of the outer detector, simulations and building the background model for WIMP & 0vbb analyses
- Significant Physics and Engineers effort - wishing to bring the definitive dual-phase TPC to Boulby mine

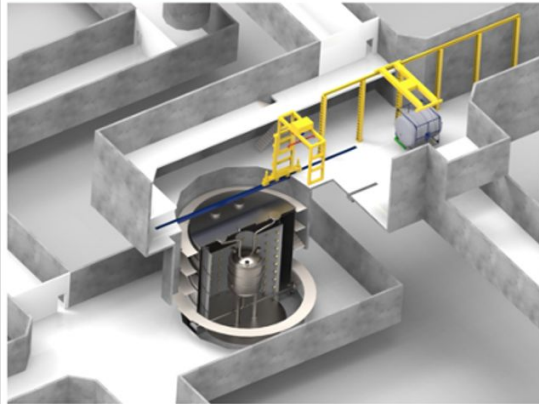

1300 m in polyhalite



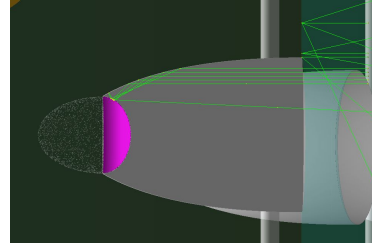
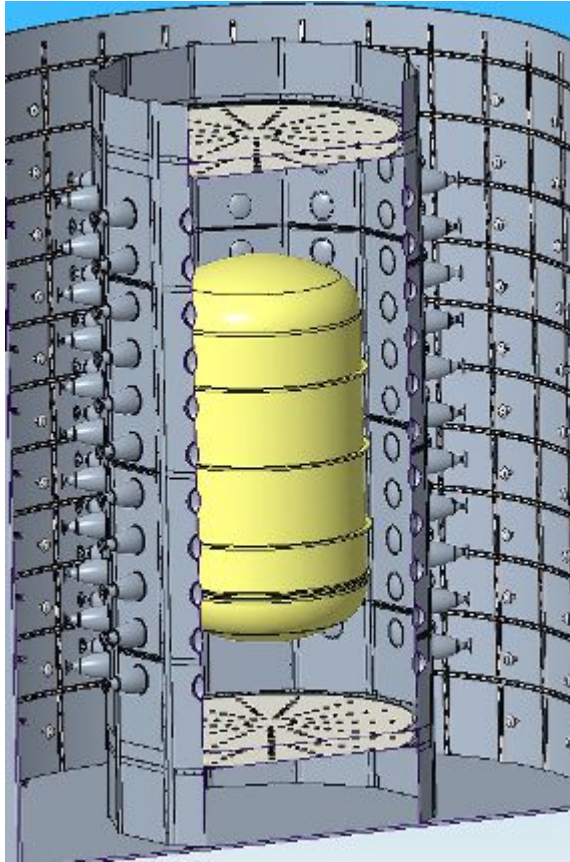

Simulations and engineering design  
in lockstep - working with James CM  
& Balint B

Geant4

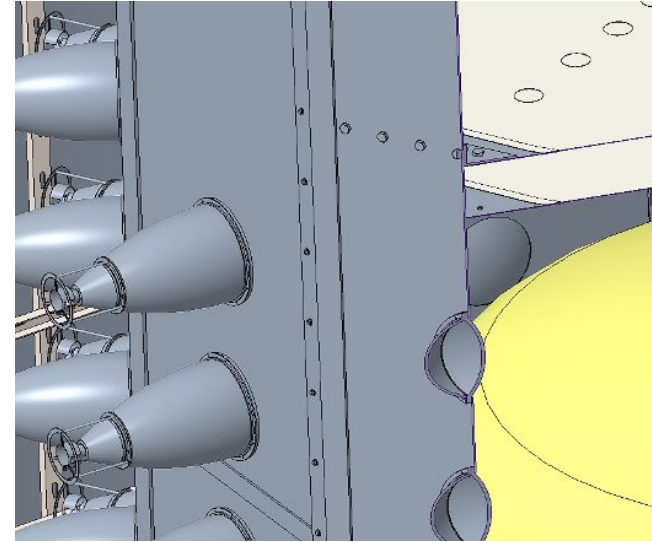
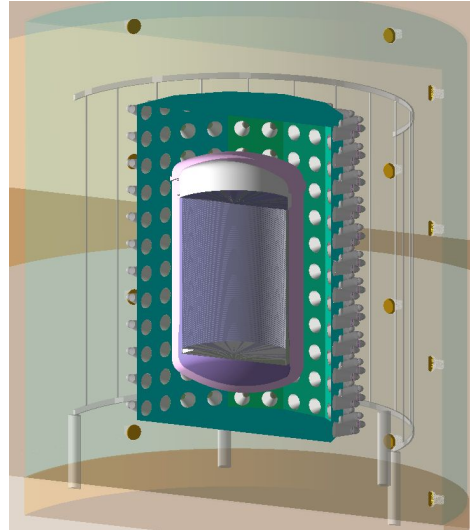

# XLZD Simulation Framework

Dedicated Geant4 simulation developed initially by Liverpool  
 Now the accepted Geant4 tool for use in the collaboration - leading internationally

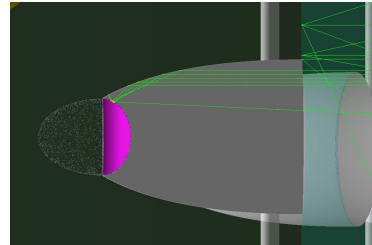

Winston Cone characterisation  
 -> EPSRC Summer Internship

Heavily utilized to build background model, and answer design questions

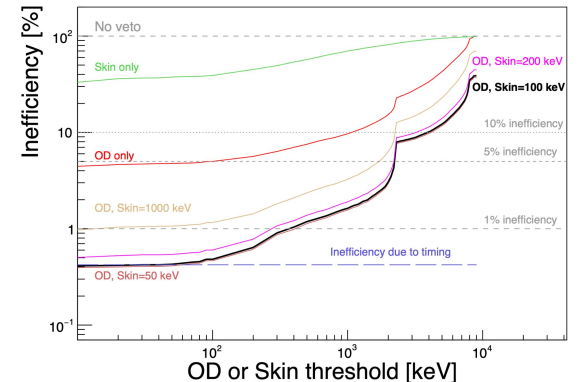
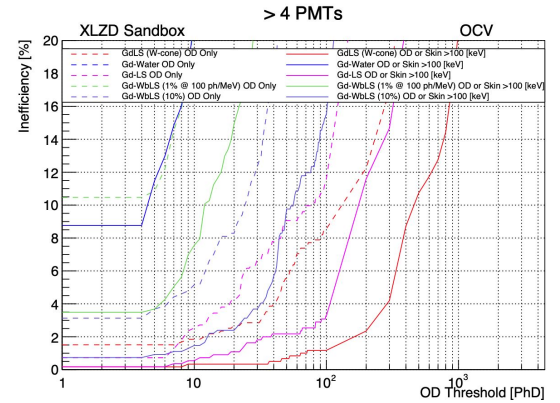
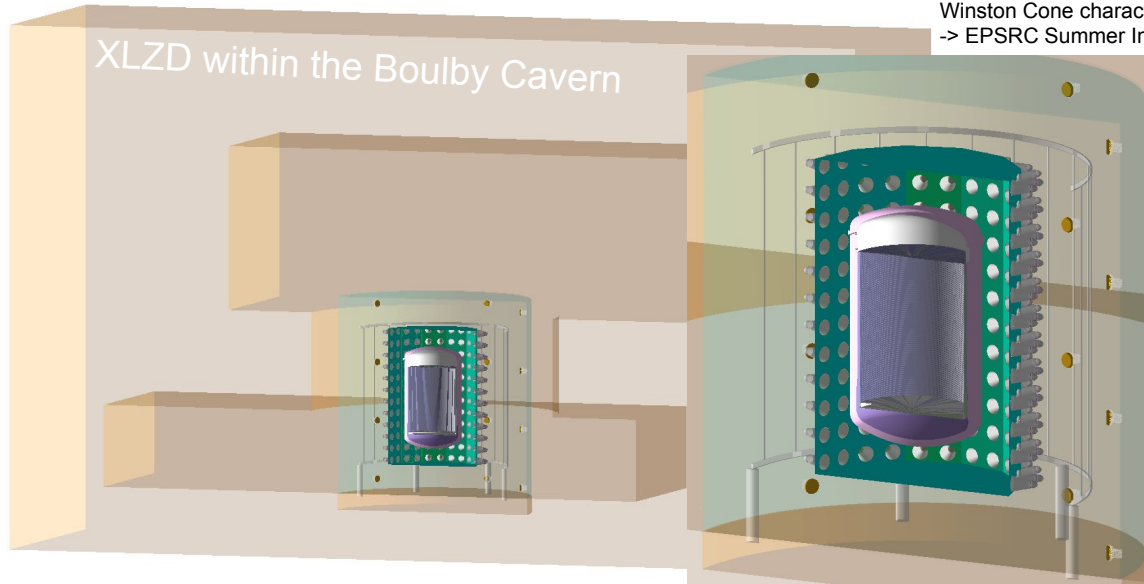

# XLZD Prototyping

Prototyping ongoing using UV Transparent acrylic box, PMTs, and selection of OD media

A novel medium is being explored: a wavelength shifting additive to Gd-Water:  
**4-Methylumbelliferone (4-MU).**

Not prohibited at LNGS.

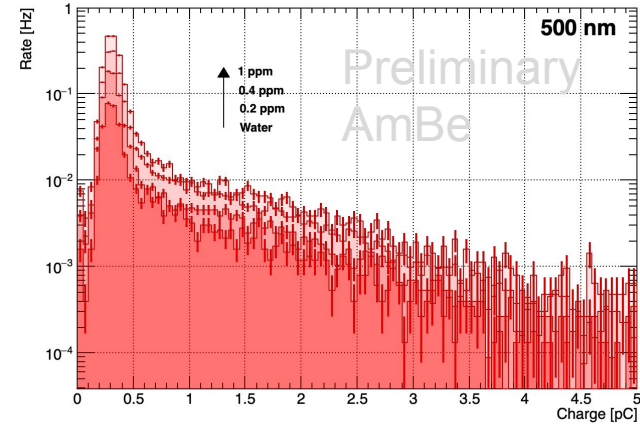
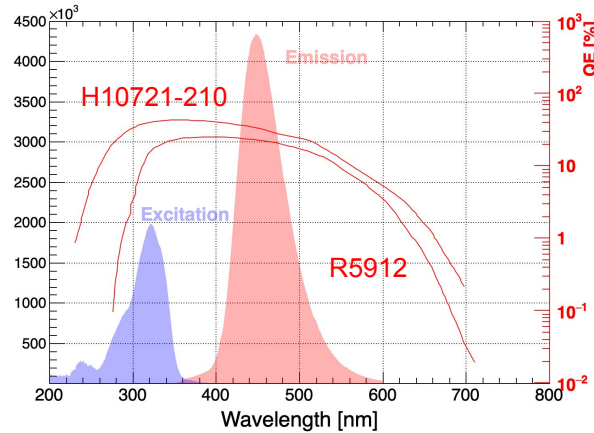

Will use Fluorimeters/UV-Vis in the MIF/CTL to build optical model of 4-MU

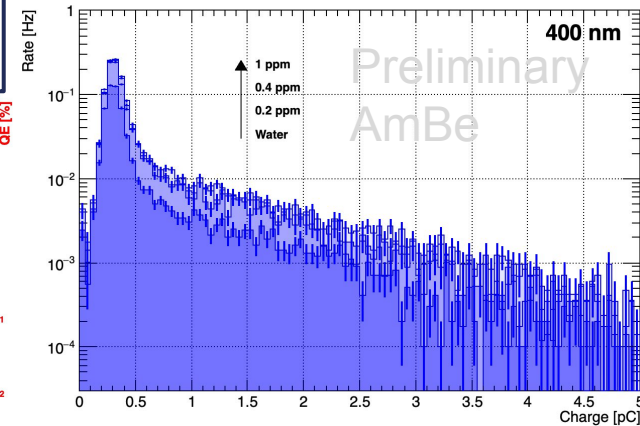
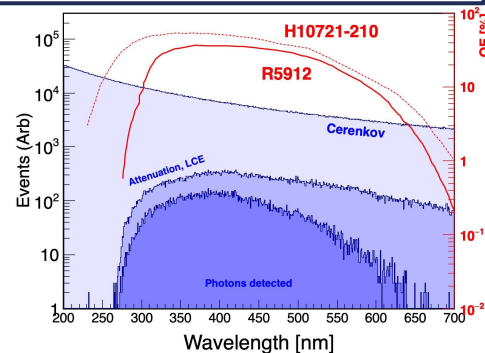

# Summary

## LZ

- World leading WIMP sensitivity
- Strongest evidence yet of  $^8\text{B}$  CEvNS interactions on Xenon nuclei
- Looking for low mass WIMPs
- Vetoes, Neutron Background
- Data Quality

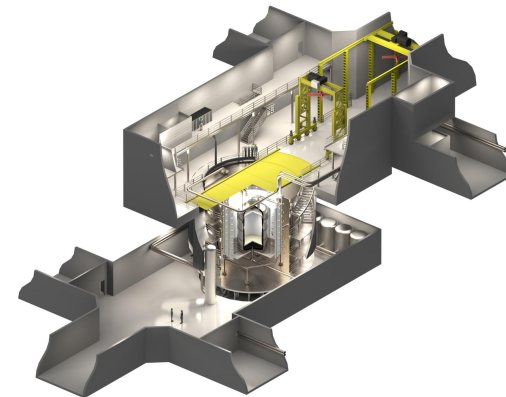

## XLZD

- Significant contributions from Liverpool towards the XLZD@Boulby preconstruction initiative
  - Development of XLZD Sandbox, use in background model generation
  - Prototyping ongoing
    - Building 4-MU optical model
- Working towards CDR for EOY completion



# XLZD Institutes



Black Hills State University  
Brookhaven National Laboratory  
Brown University  
Bucknell University  
Columbia University  
Laurentian University  
Lawrence Berkeley National Laboratory  
Lawrence Livermore National Laboratory  
McGill University  
McMaster University  
Pennsylvania State University  
Queen's University  
Rice University  
SLAC National Accelerator Laboratory  
SNOLAB  
Sanford Underground Research Facility  
South Dakota School of Mines  
TRIUMF  
The University of Chicago  
University of Alabama  
University of Alberta  
University of British Columbia  
University of California, Berkeley  
University of California, Los Angeles  
University of California, San Diego  
University of California, Santa Barbara  
University of Maryland  
University of Massachusetts  
University of Michigan  
University of Rochester  
University of Texas, Austin  
University of Windsor  
University of Wisconsin  
Université de Montreal  
Université de Sherbrooke



Heidelberg University  
INAF Osservatorio Astrofisico Torino  
INFN-LNGS  
Imperial College London  
Johannes Gutenberg University Mainz  
Karlsruhe Institute of Technology  
King's College London  
LIP-Coimbra  
LPNHE  
Max-Planck-Institut für Kernphysik  
Nikhef & the University of Amsterdam  
Nikhef & the University of Groningen  
Queen Mary University of London  
Royal Holloway, University of London  
SISSA  
STFC Laboratories  
SUBATECH  
Stockholm University  
TU Darmstadt  
TU Dresden

University College London  
University and INFN Bologna  
University of Barcelona  
University of Bern  
University of Birmingham  
University of Bristol  
University of Coimbra  
University of Edinburgh  
University of Ferrara  
University of Freiburg  
University of L'Aquila  
University of Liverpool  
University of Münster  
University of Naples "Federico II"  
University of Oxford  
University of Sheffield  
University of Sussex  
University of Zurich  
Vinca Institute of Nuclear Sciences  
Weizmann Institute



Institute for Basic Science  
Kobe University  
Nagoya University  
The Chinese University of Hong Kong, Shenzhen  
The University of Tokyo  
Tsinghua University  
Westlake University



The University of Melbourne  
The University of Sydney