

ATOM INTERFEROMETRY: MAGIS, LIVERPOOL & FUTURE PROSPECTS

JONATHAN TINSLEY
JONATHAN.TINSLEY@LIVERPOOL.AC.UK



- **Areas of activity:**
 - MAGIS collaboration at Fermilab
 - AION consortium in the UK
 - Proto-collaborations TVLBAI and AICE at CERN
 - In-house programme – 2nd Floor Oliver Lodge
- **Personnel changes:**
 - Chetan Parmar joined as a PhD student
 - Henry Throssell successfully passed his PhD viva
 - Now working at Quantum Fabrix
 - Gedminas Elertas left to industry
 - Astrolight in Lithuania
 - Andrew Carroll left at end of position

Plus crucial input from the Detector Development and Manufacturing Facility



Kieran Bridges



Jon Coleman



Kamran Hussain



Carl Metelko



Chetan Parmar



Jonathan Tinsley

CLOCK ATOM INTERFEROMETRY

- Emerging new form of quantum sensor combining clock and atom interferometry technology

TIME

Inertial Forces

Optical atomic clocks

Interference of internal electronic states

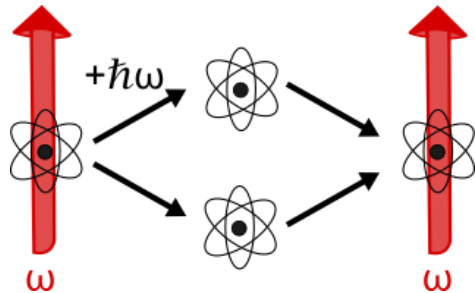

Atom interferometers

Interference of external momentum states

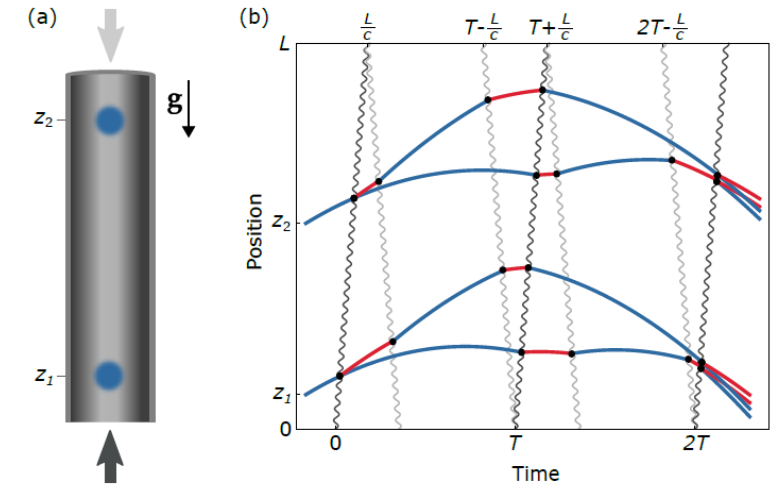
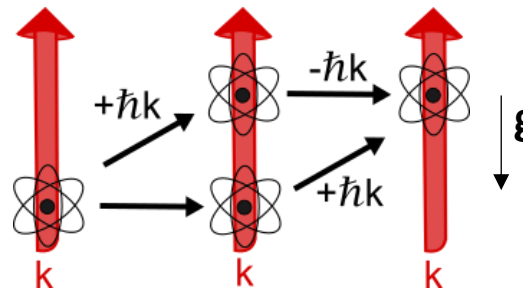

M. Abe *et al.*, Quantum Sci. Technol. **6**, 044003 (2021)

Clock atom interferometry **combines sensitivity** to inertial forces with superpositions of optical energy levels **and** allows for **very long-baseline** atom interferometers

- **Broad new physics programme**
- Sensitive to **wavelike ultralight dark matter**
 - Scalar \rightarrow changes of fundamental constants
 - Vector \rightarrow different inertial forces on isotopes
 - Pseudoscalar \rightarrow couples to different spins
- Sensitive to **mid-band gravitational waves**
 - GWs cause a change in laser propagation time
 - Complimentary to light interferometers
 - Full exploitation will require km-scale terrestrial detectors

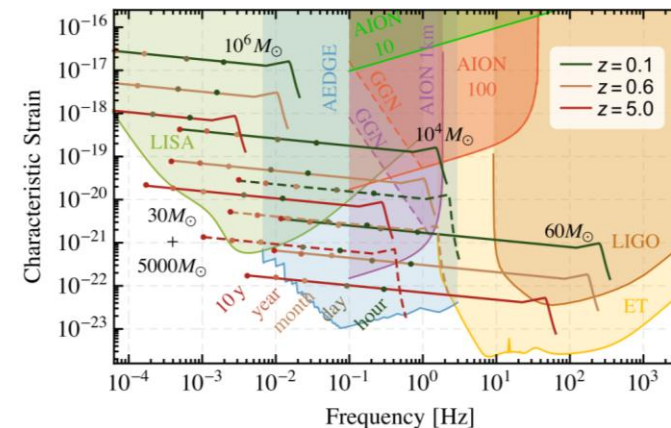
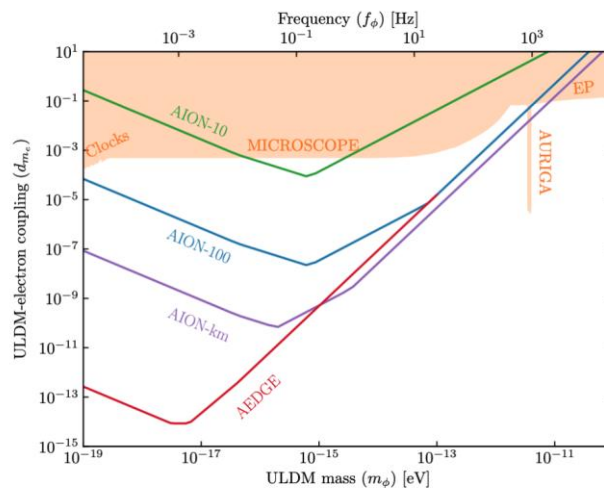
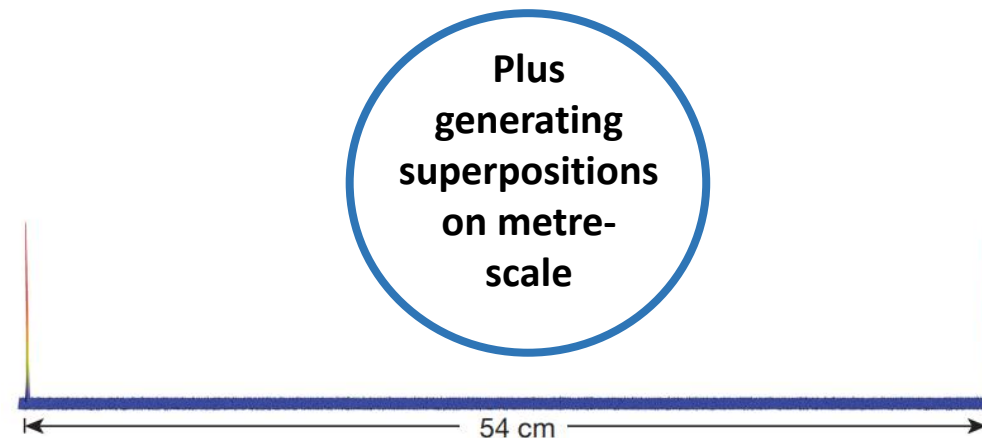

L. Badurina *et al.*, *Journal of Cosmology and Astroparticle Physics* **011** (2020)

A. Balaz *et al.*, *AVS Quantum Science* **6**, 024701 (2025)

T. Kovachy *et al.*, *Nature* **528**, 530-533 (2015)

- MAGIS-100 is US-UK collaboration for **a 100-m baseline clock atom interferometer**
- Housed in the MINOS building and shaft at **Fermilab**
- **Funding commitment** from DOE for construction: \$18 mn
- **Construction started**, mature experimental design
- Commissioning and data collection **to start in early 2028**



Matter wave **A**tomic **G**radiometer **I**nterferometric **S**ensor

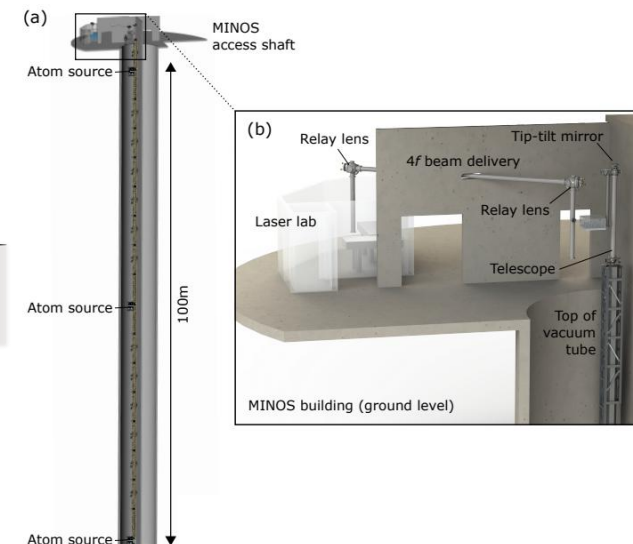
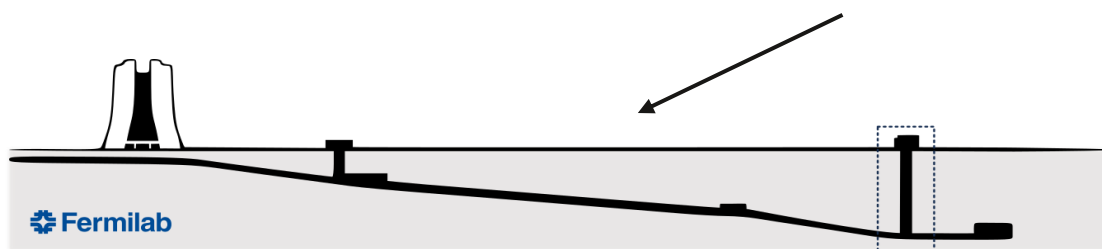

- Jon Coleman leads MAGIS-UK – UK has responsibility for detection platform
- Liverpool leads on retro-reflection detection chamber and its control
- Design, prototyping, manufacturing, assembly and commissioning
- Engineering and machining custom in-vacuum components
- Top tip-tilt platform machining and procurement

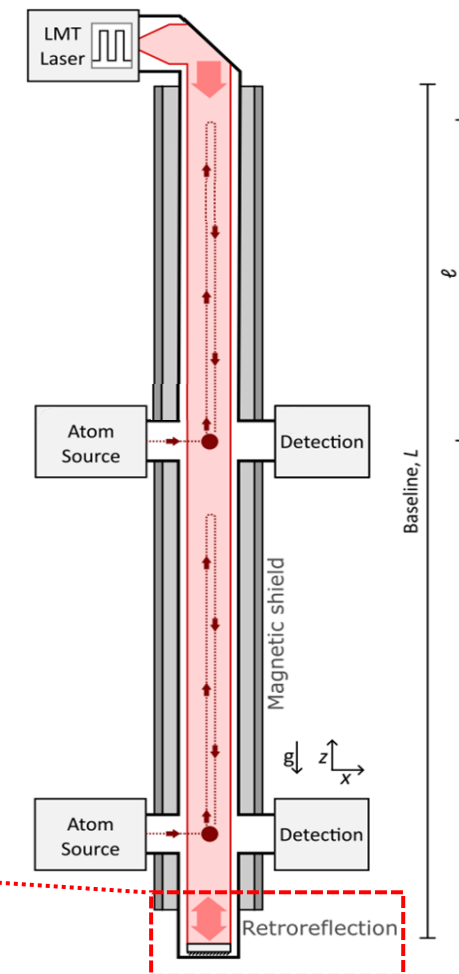
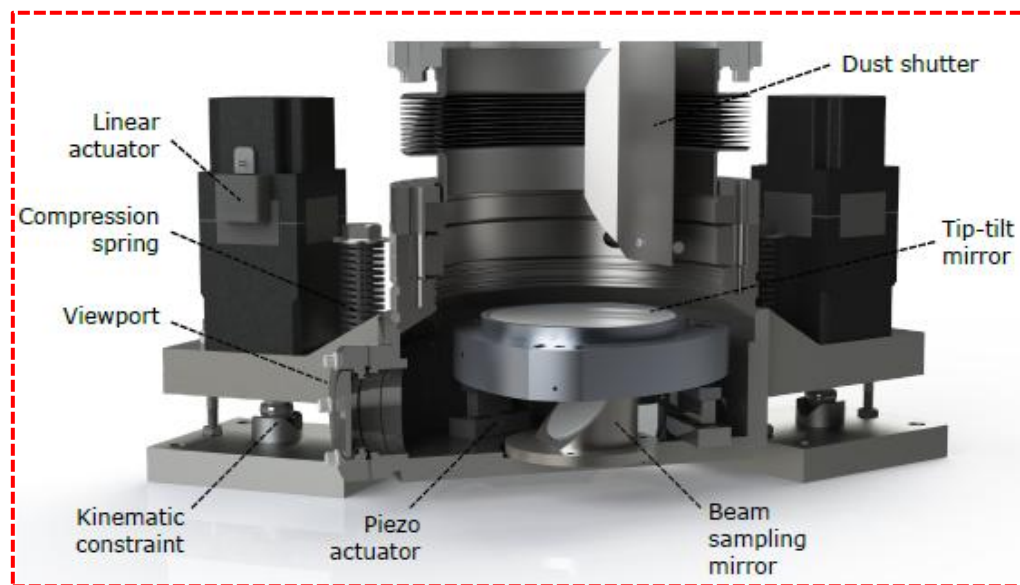

- Multi-purpose system for countering systematics and aiding interferometer readout

Coriolis Compensation

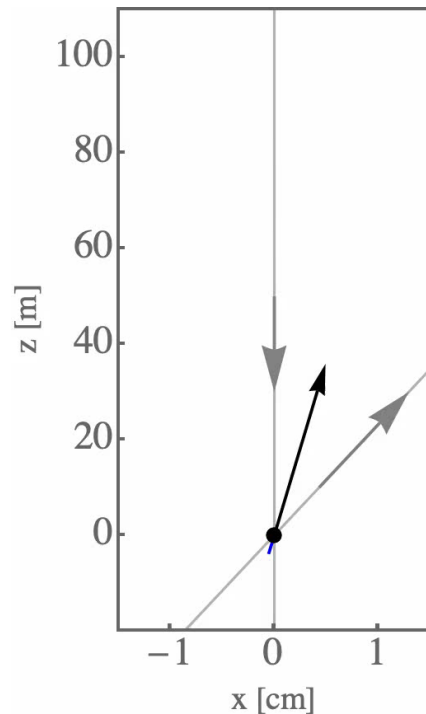

J. Glick *et al.*, AVS Quantum Science **6**, 014402 (2024)

Precision Beam Alignment

Phase Shear Readout

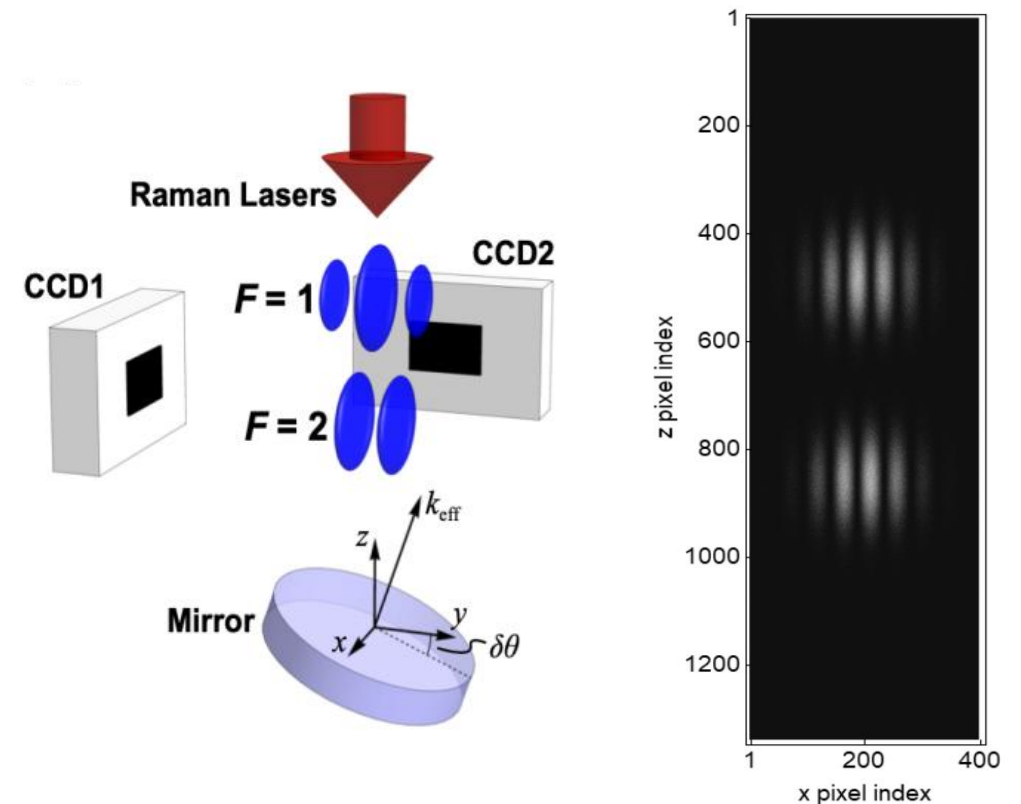

A. Sugarbaker *et al.*, Phys. Rev. Lett. **111**, 113002 (2013)

- Chamber assembled and tested at MAGIS 10-m prototype at Stanford
 - Measured performance in specification
- To be commissioned in now-vertical tower
- Optical monitoring system also developed

Requirement	Design Target	Measured
angular range ϕ (mrad)	1.3	1.4
rms average $\delta\phi$ (nrad)	50	33
rms mirror flatness (λ)	0.001	0.001 ± 0.001
servo settling time (ms)	100	63.4 ± 3.4

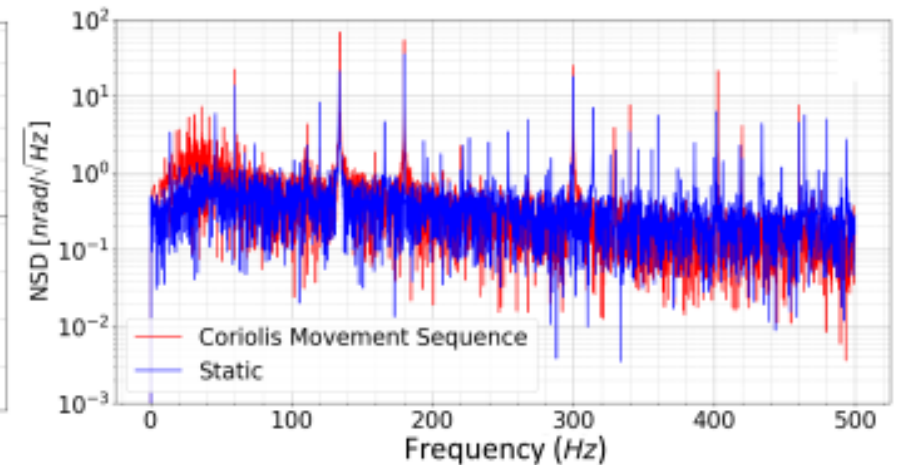
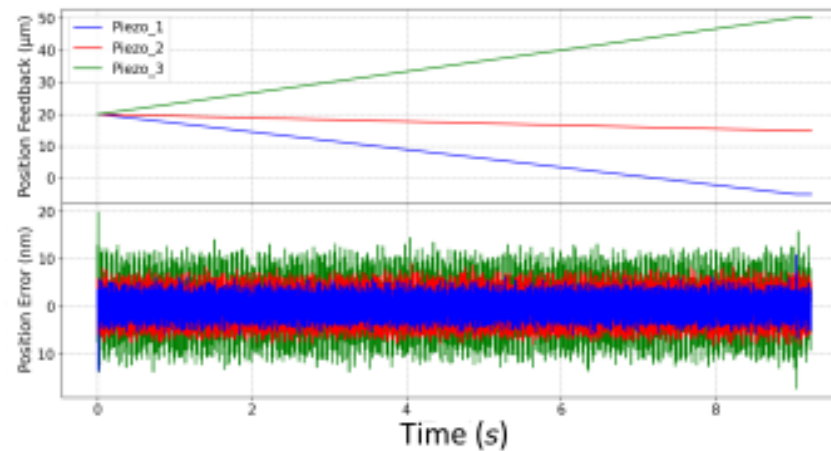
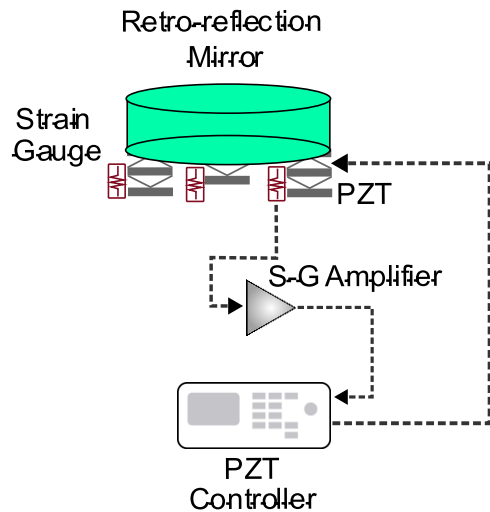

- Analysis of how chamber pointing jitter transfers to atom interferometer noise
- Device performance suitable for MAGIS-100 initial configurations
- Developing analysis mitigation strategies

Collaboration with N. Mouelle and J. Mitchell at the University of Cambridge

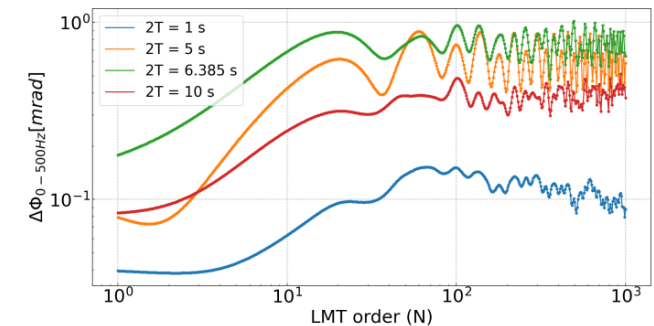
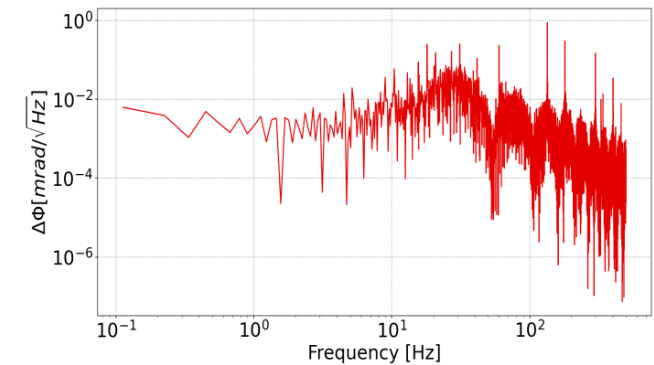
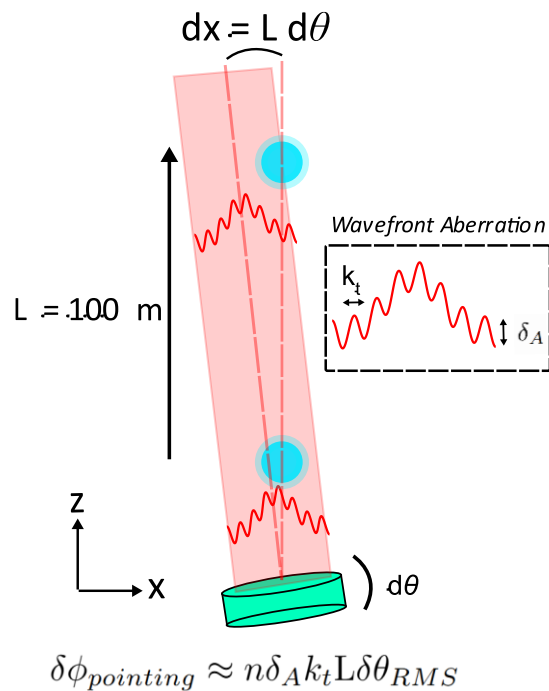
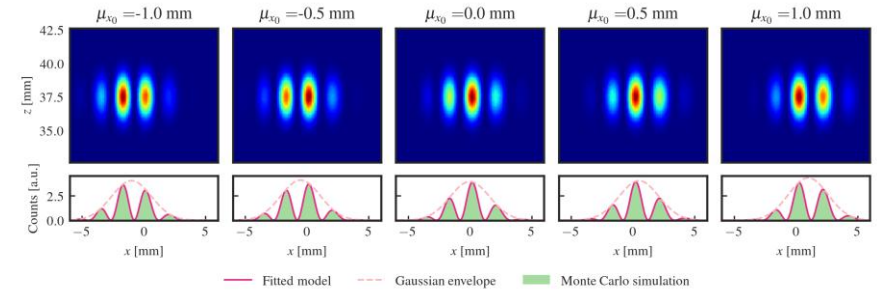

- Coordinating the Offline Coordination Group
- Responsibility for offline infrastructure and simulation and analysis
- Developing a Bayesian inference analysis pipeline for scalar dark matter search

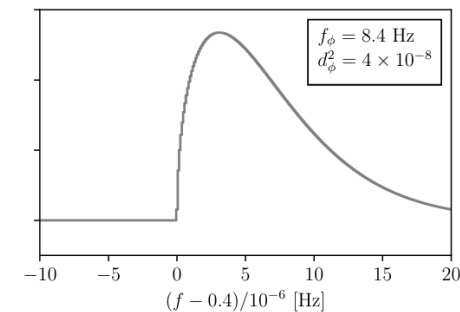
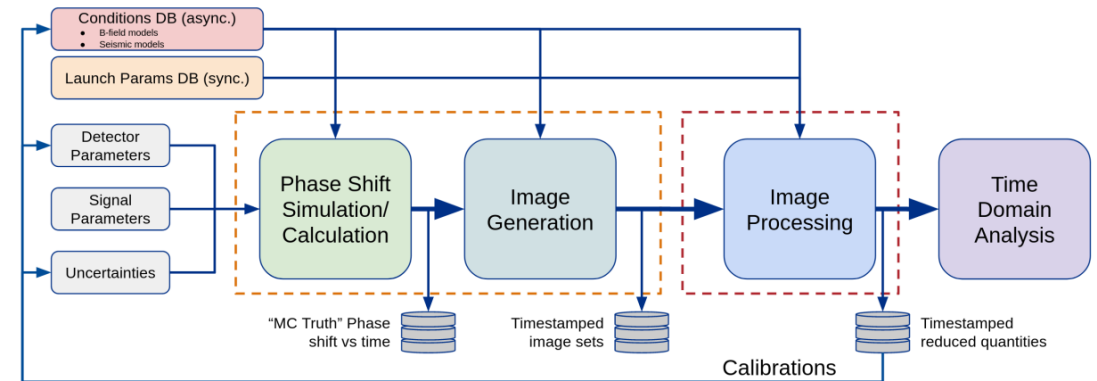
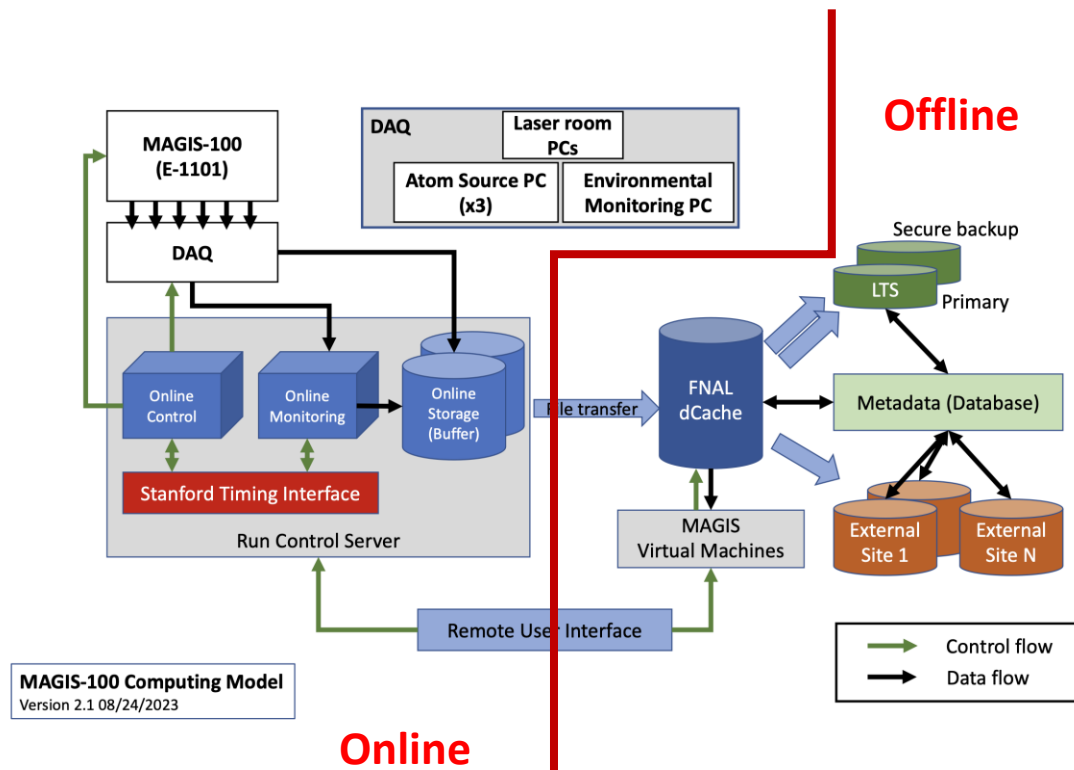

L. Badurina *et al.*, PRD **108**, 083016 (2023)

- AION is a UK consortium with five 1-m prototypes, which will provide a second node
- Performed a proof-of-principle atom interferometer and dark matter analysis
- Delivered a technical design review for a 10-m tower at Oxford
- Atom source simulation and calibration in collaboration with RAL
- Current funding gap – awaiting potential new QTFP call

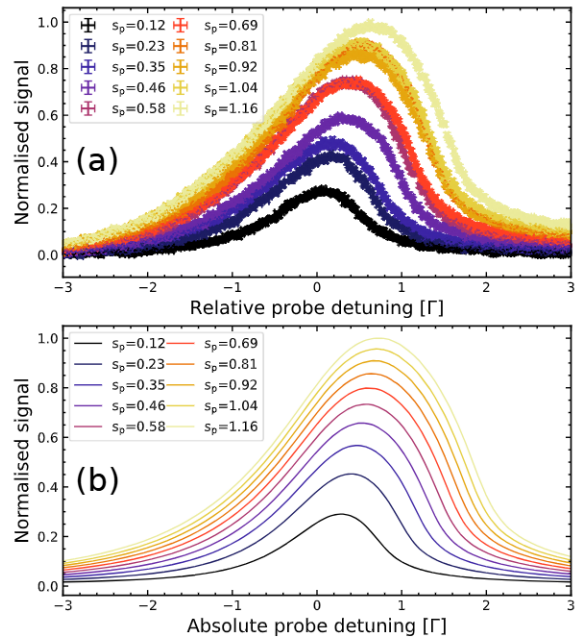

K. Hussain *et al.*, *in preparation*



K. Bongs *et al.*, *arXiv:2508.03491* (2025)

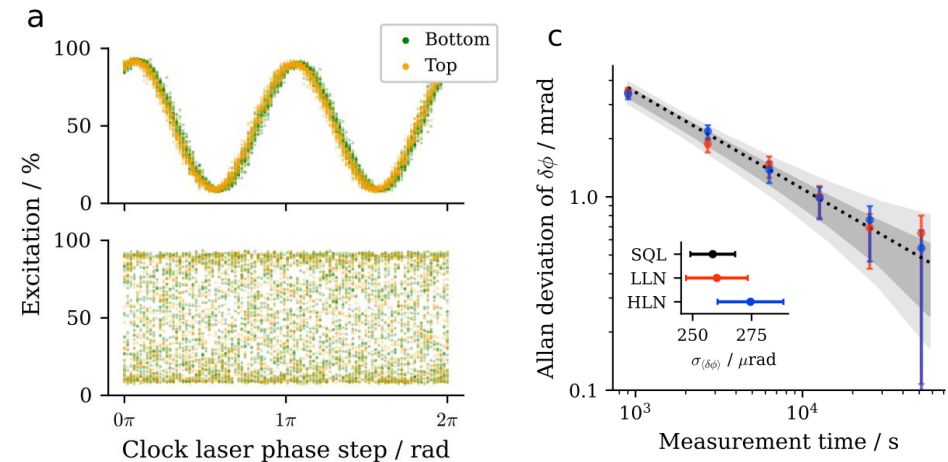

C. F. A. Baynham *et al.*, *arXiv:2504.09158* (2025)

- Letter of Intent submitted for a 100-m atom interferometer at CERN
- To be installed in the PX46 access shaft – site analysis performed
- Engineering work would occur during LS3, estimated cost ~ 1.2 mn CHF
- Invited to submit a Technical Review and a workshop to be held at CERN in September

Letter of Intent:

AICE - Atom Interferometer CERN Experiment

Charles Baynham,¹ Andrea Bertoldi,² Diego Blas,³ Oliver Buchmueller*,^{1,4} Sergio Calatroni,⁵ Vassilis Charmandaris,⁶ Maria Luisa (Marilù) Chiofalo,⁷ Pierre Cladé,⁸ Jonathon Coleman,⁹ Fabio Di Pumpo,¹⁰ John Ellis*,¹¹ Naceur Gaaloul,¹² Saïda Guellati-Khelifa,⁸ Tiffany Harte,¹³ Richard Hobson,¹ Michael Holynski,¹⁴ Samuel Lellouch,^{14,15} Lucas Lombriser,^{16,17} Elias Lopez Asamar,¹⁸ Michele Maggiore,^{17,19} Christopher McCabe,¹¹ Jeremiah Mitchell,¹³ Ernst M. Rasel,¹² Federico Sanchez Nieto,^{17,19} Wolfgang Schleich,²⁰ Dennis Schlippert,¹² Ulrich Schneider,¹³ Steven Schramm,^{17,19} Marcelle Soares-Santos,²¹ Guglielmo M. Tino,²² Jonathan N. Tinsley,⁹ Tristan Valenzuela,²³ Maurits van der Grinten,²⁴ Wolf von Klitzing,²⁵

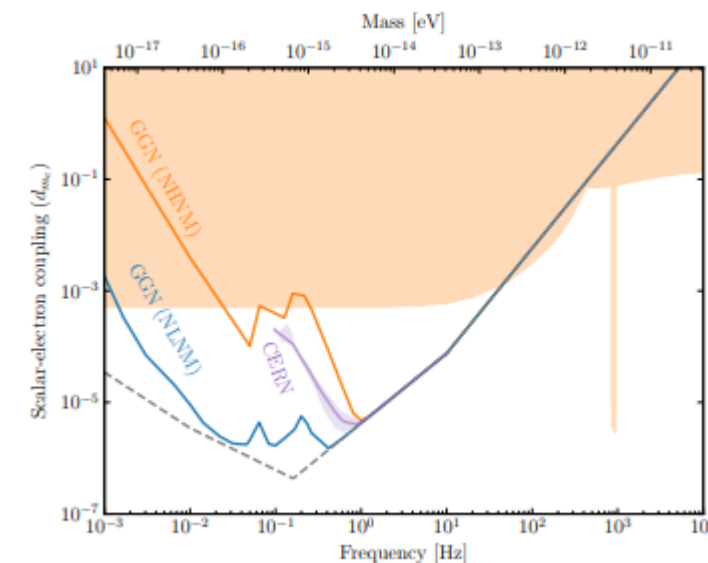
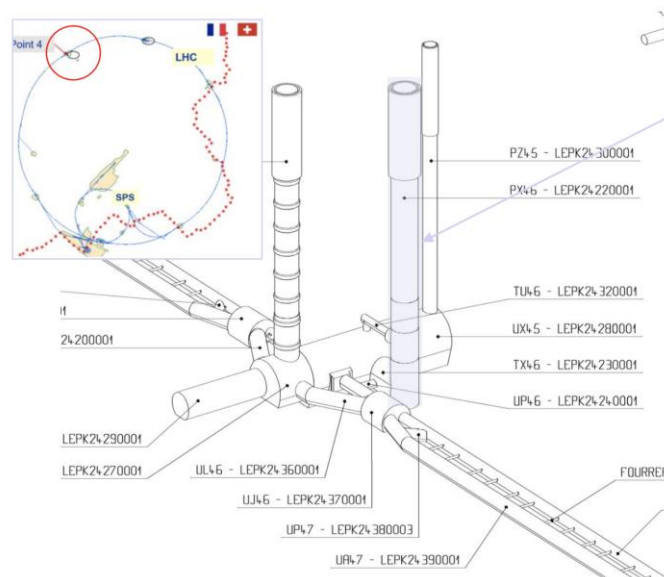

C. Baynham *et al.*, arXiv:2509.11867 (2025)

- MAGIS-100 is a pathfinder for **mid-band gravitational wave** detection to **bridge gap** between LIGO and LISA
- International proto-collaboration formed (TVLBAl) towards **km-scale terrestrial atom interferometry global network**
- Regular international workshops hosted
- Considerable interest for **space-based missions** such as AEDGE

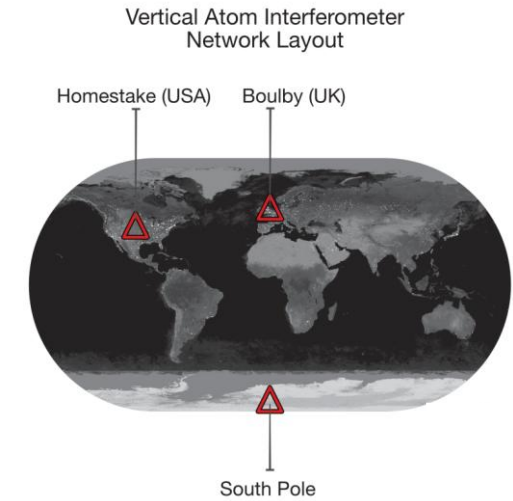

C. A. Argüelles *et al.*, arXiv:2605.14279 (2026)

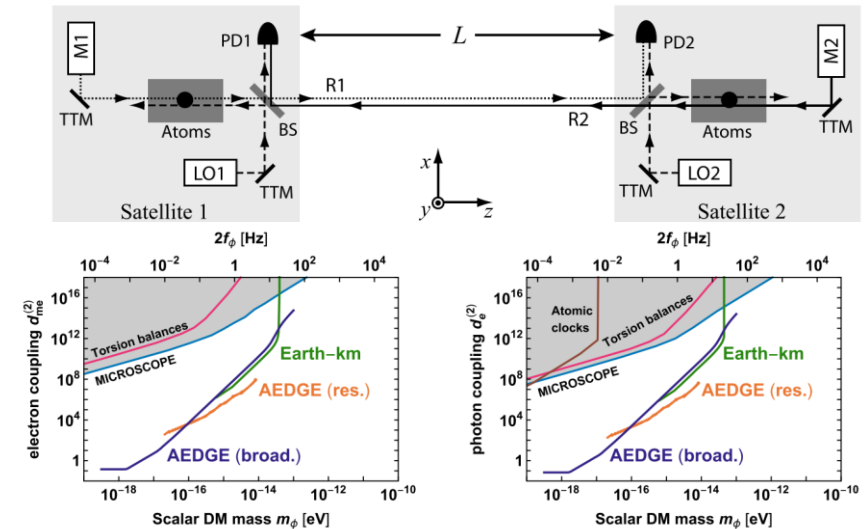
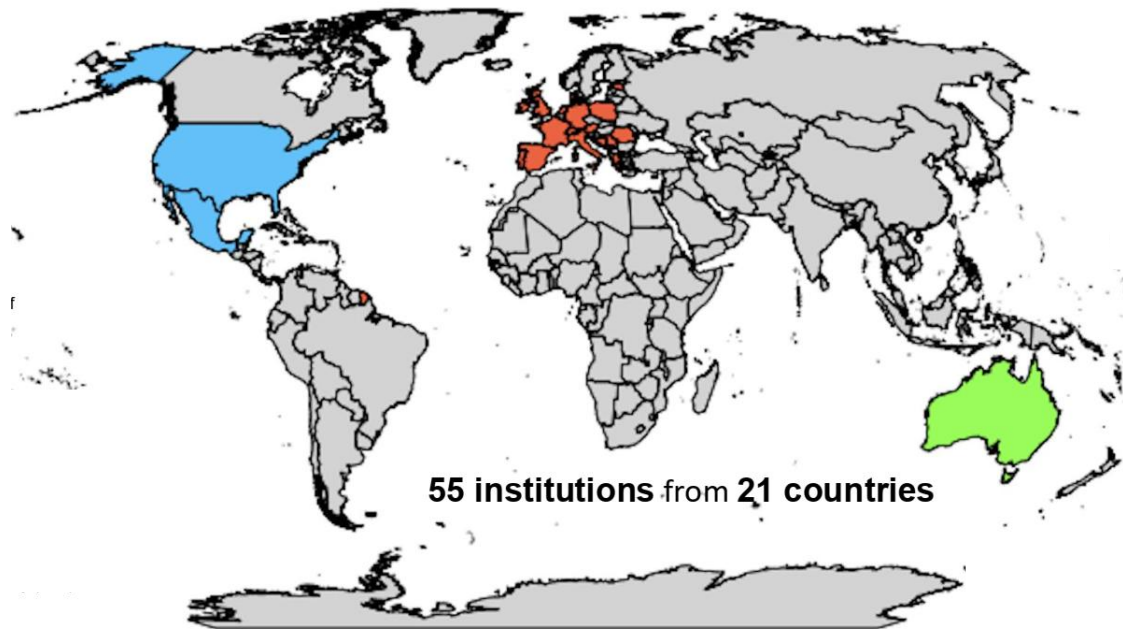

Y. A. El-Neaj *et al.*, EPJ Quantum Technology 7, 6 (2020)

LIVERPOOL'S ATOM INTERFEROMETER

- Liverpool hosts a 1-m rubidium atom interferometer
- Vacuum chamber from NPL's atomic clock programme

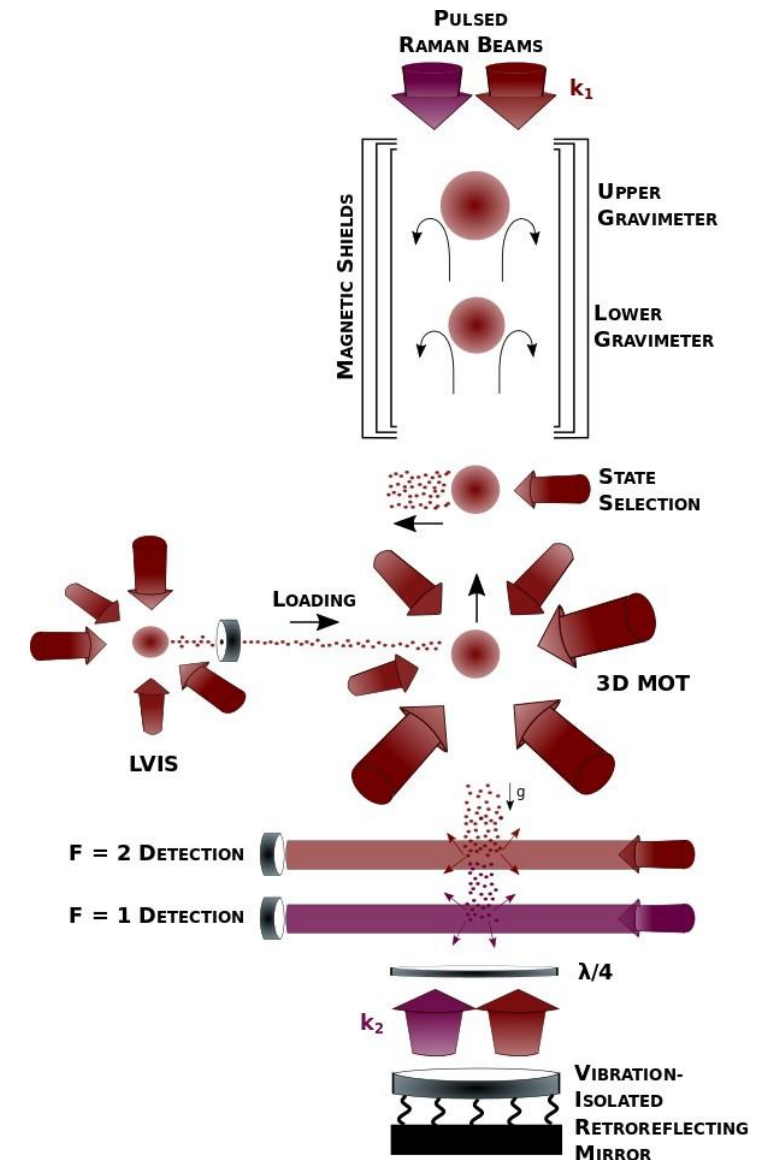
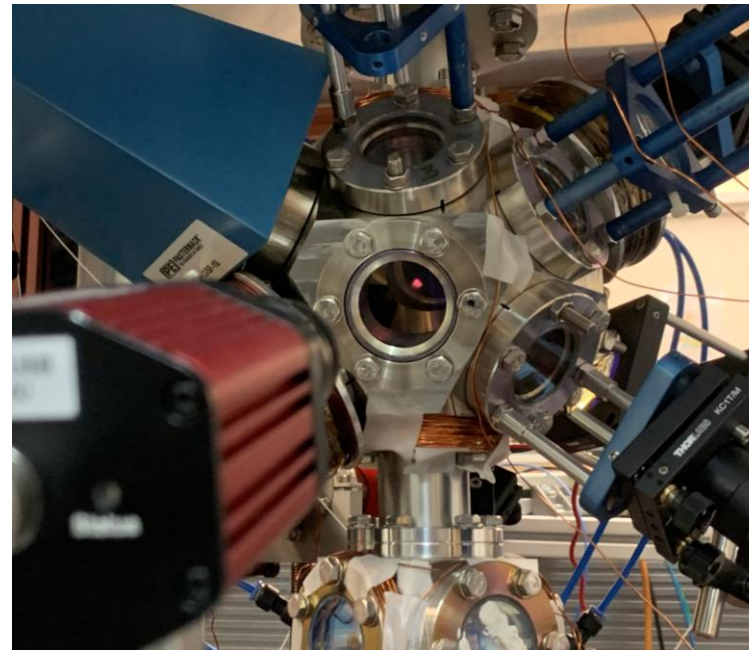
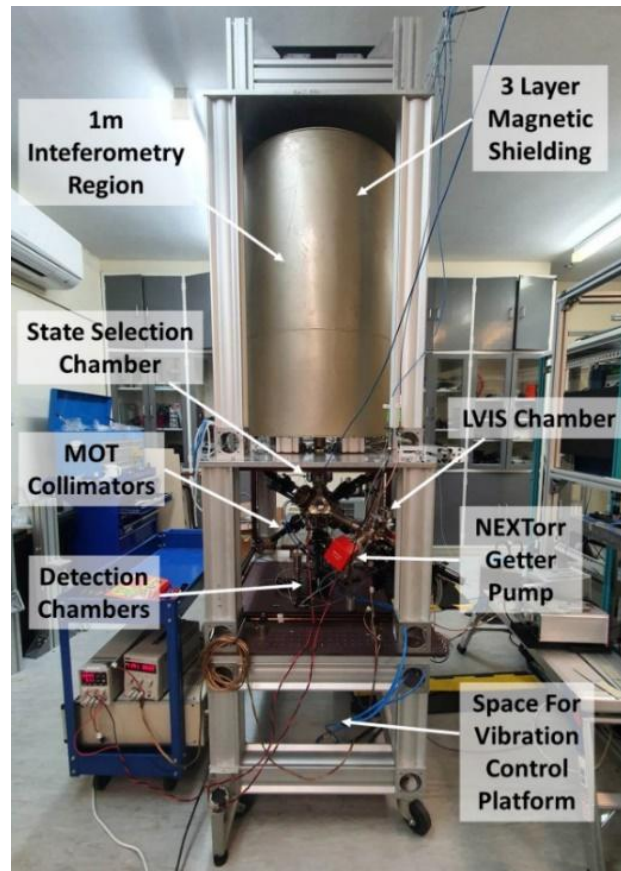

Main Upgrades:

- Factor 5 increase in experimental repetition rate and automated experimental control
- Cancellation of Earth's magnetic field via RF spectroscopy
- Velocity and quantum state selection implemented
- Chirped Raman beams → Two orders of magnitude increase in interferometry time

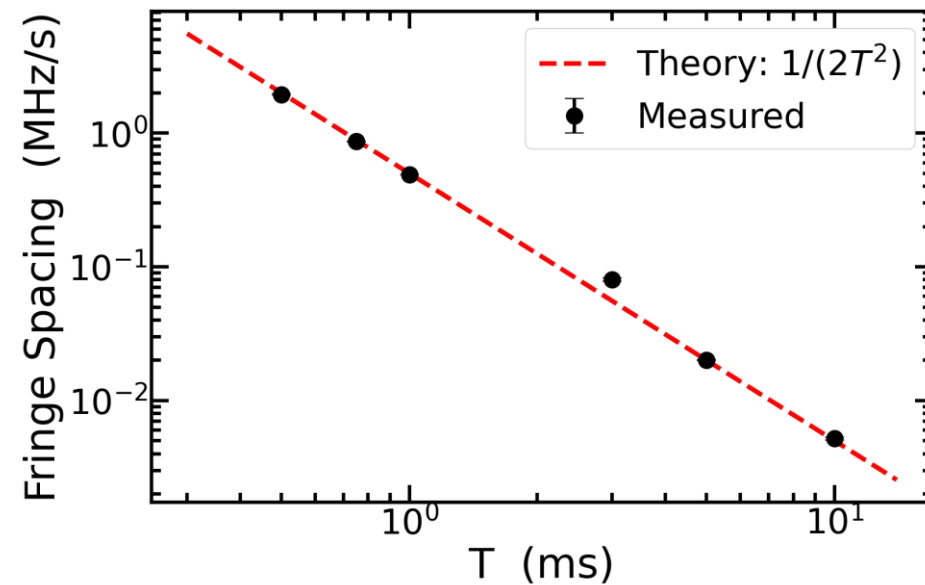
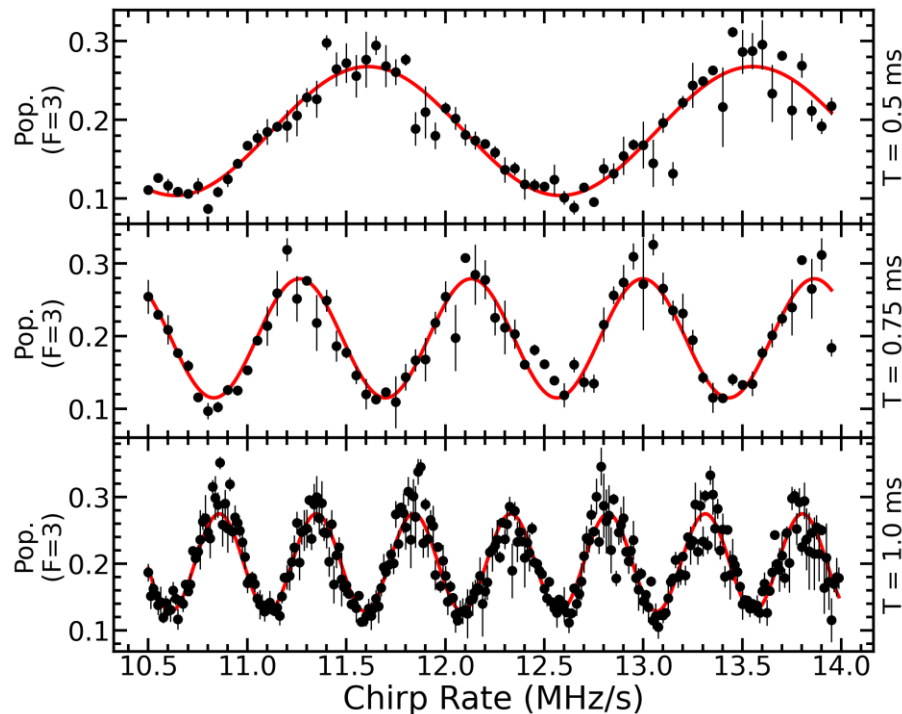

May 2026: Tracked freefall acceleration over ~30 minutes

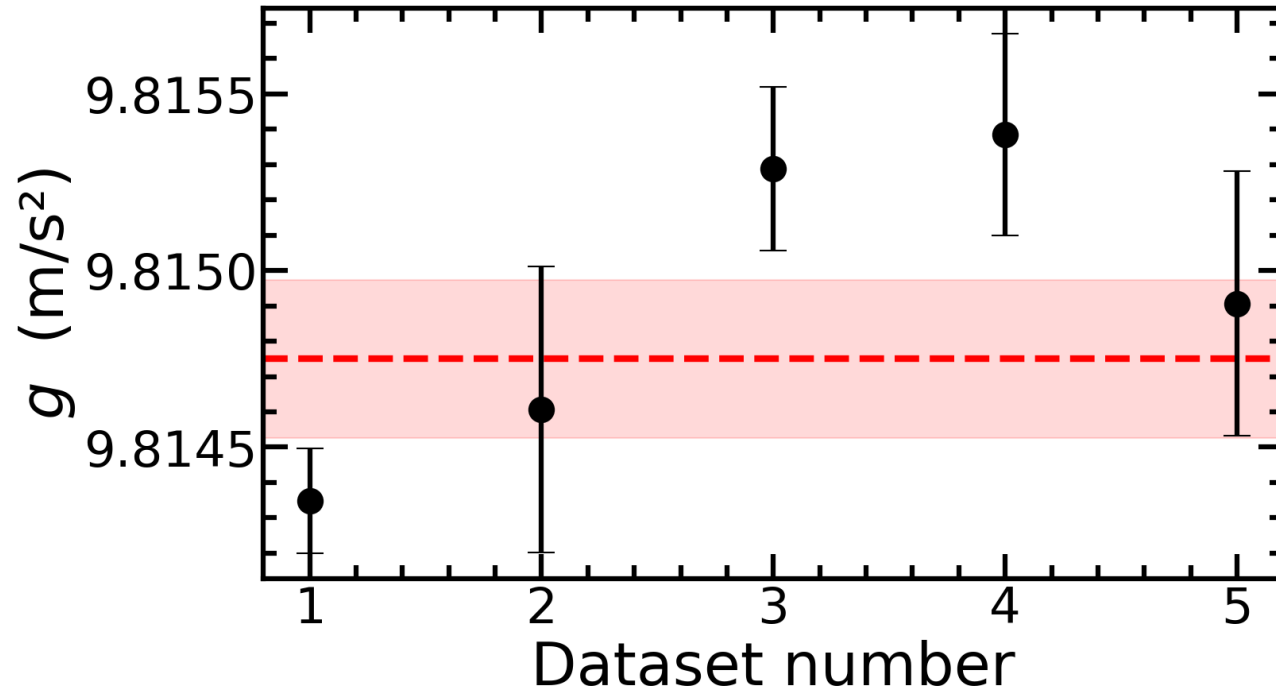

Note: Preliminary - systematic analysis to be finalised.

Next Steps:

- Commission active vibration isolation
- Measurement campaign against a classical gravimeter
- Install out-of-vacuum actuated retroreflection platform
- Launch atoms to 1 m
- Juggle atoms
- Test novel noise cancellation and readout techniques
- Should be able to improve errors by several orders of magnitude in the coming months

- Long-baseline clock atom interferometers have the potential to search for wide variety of new physics:
 - Ultralight dark matter searches
 - Gravitational waves detection prototyping
 - Fundamentals of quantum mechanics
- Next few years promise to be a very exciting time for the field:
 - MAGIS to begin commissioning in 2027
 - Major new international collaborations forming
- Important advances at Liverpool
 - Inertially sensitive interference fringes sets us up as a testbed
 - Will be implementing our phase-shear platform
 - Implementing new wavefront aberration cancellation methodologies

