

T2K, Super-K and Hyper-K

HEP Annual Meeting 2026

21/5/26

Sam Jenkins



Hyper-Kamiokande



Group members





Academics:

-  Neil McCauley
-  Christos Touramanis
-  Kostas Mavrokoridis
-  Jon Coleman

Research/technical staff:

-  Sam Jenkins
-  David Payne
-  Ellen Sandford 🙌😭
-  Balint Bogdan
-  Carl Metelko
-  Joe Walsh (MSU, visiting researcher)

PhD students:

-  Patrick Bates
-  Unik Limbu
-  Naomi Foster

T2K summary



- Long-baseline neutrino oscillation experiment
- Beam of muon (anti-)neutrinos produced at JPARC, directed toward the Super-Kamiokande far detector 295 km away
- Near detector complex situated 280 m downstream of beam
- Beam is directed 2.5° off-axis from SK and ND280 to achieve narrow-band beam
- Peak neutrino energy of 600 MeV

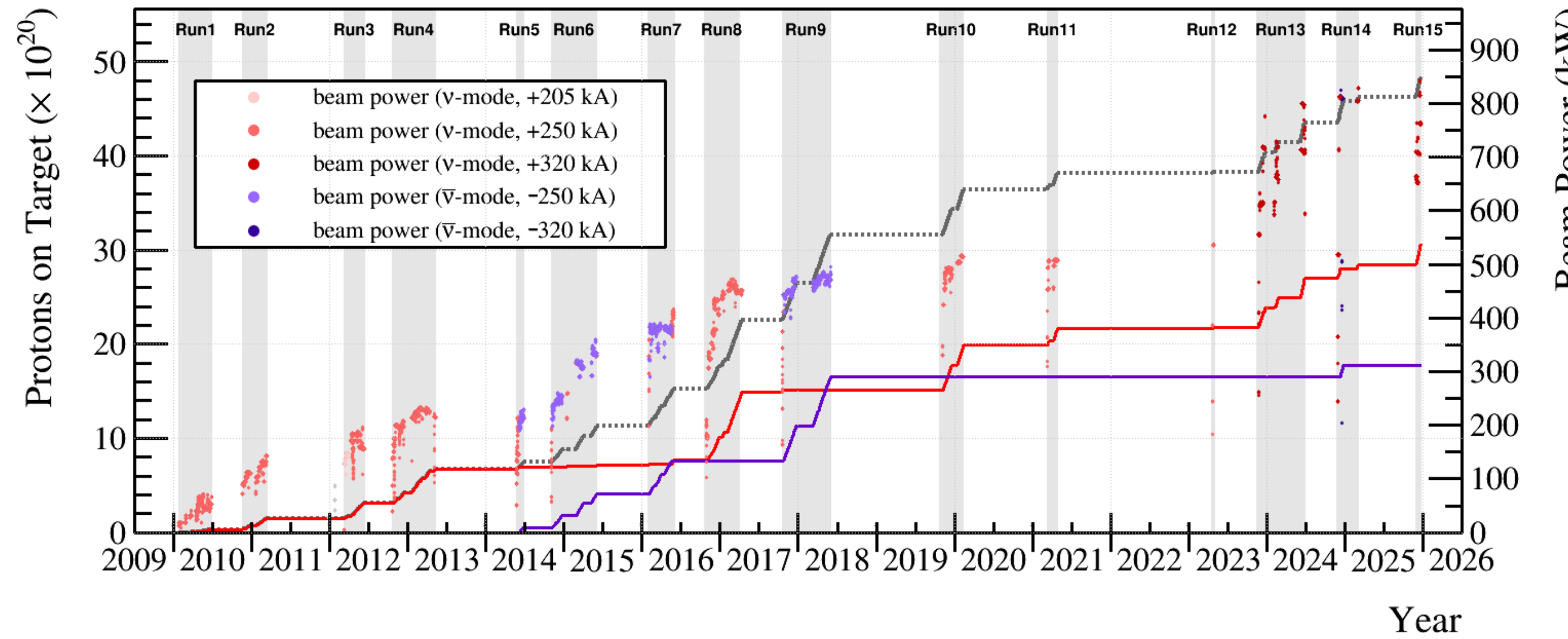
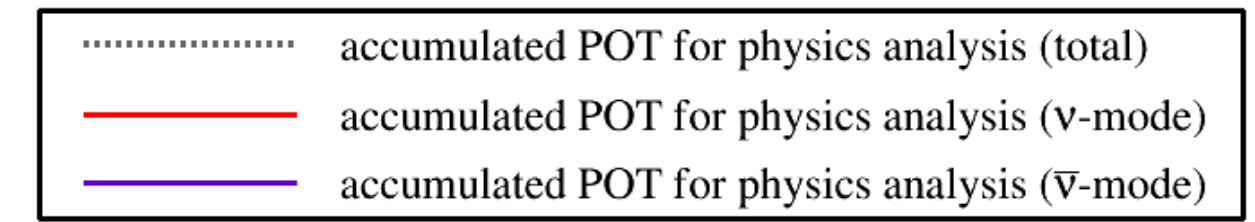
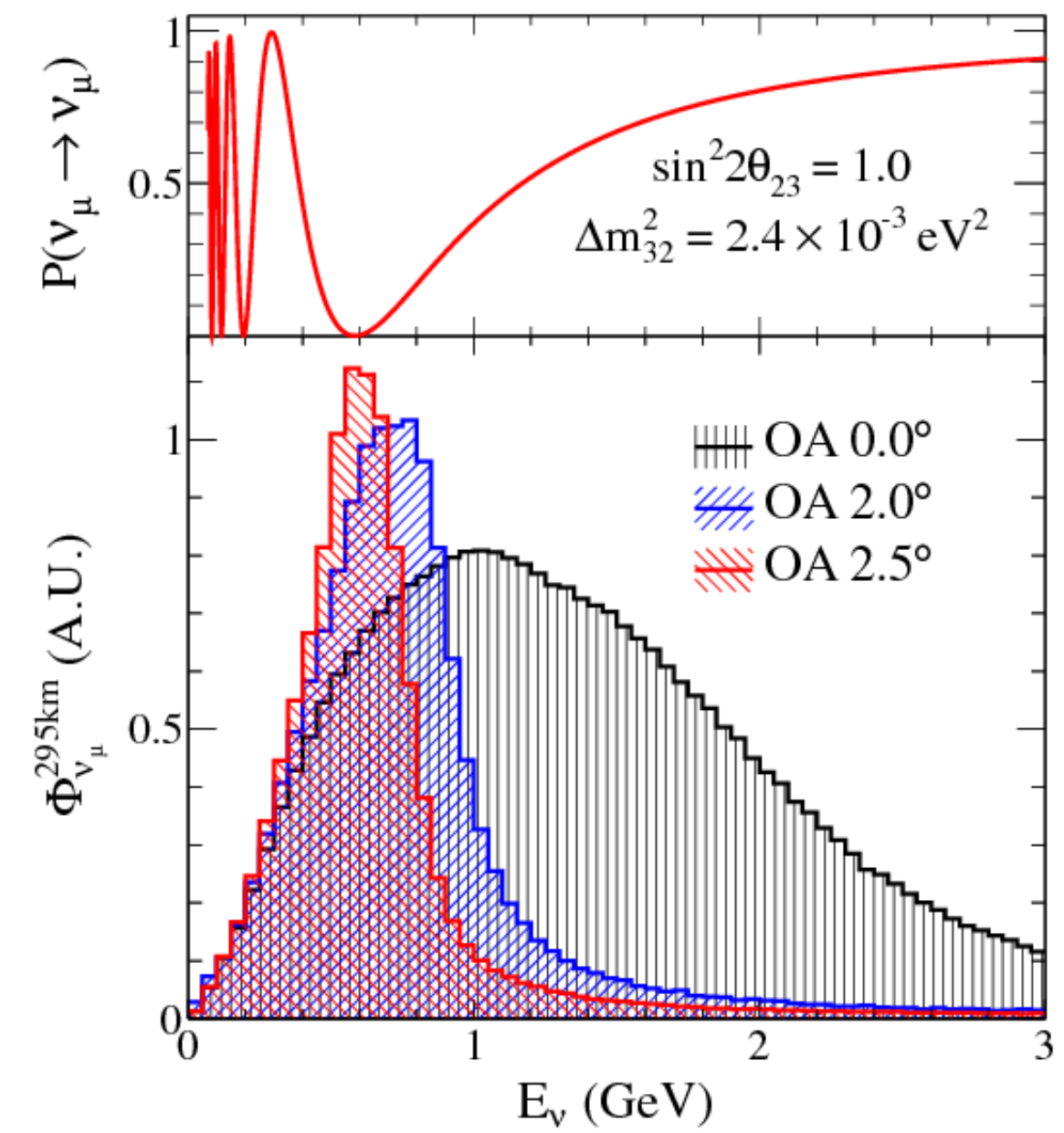
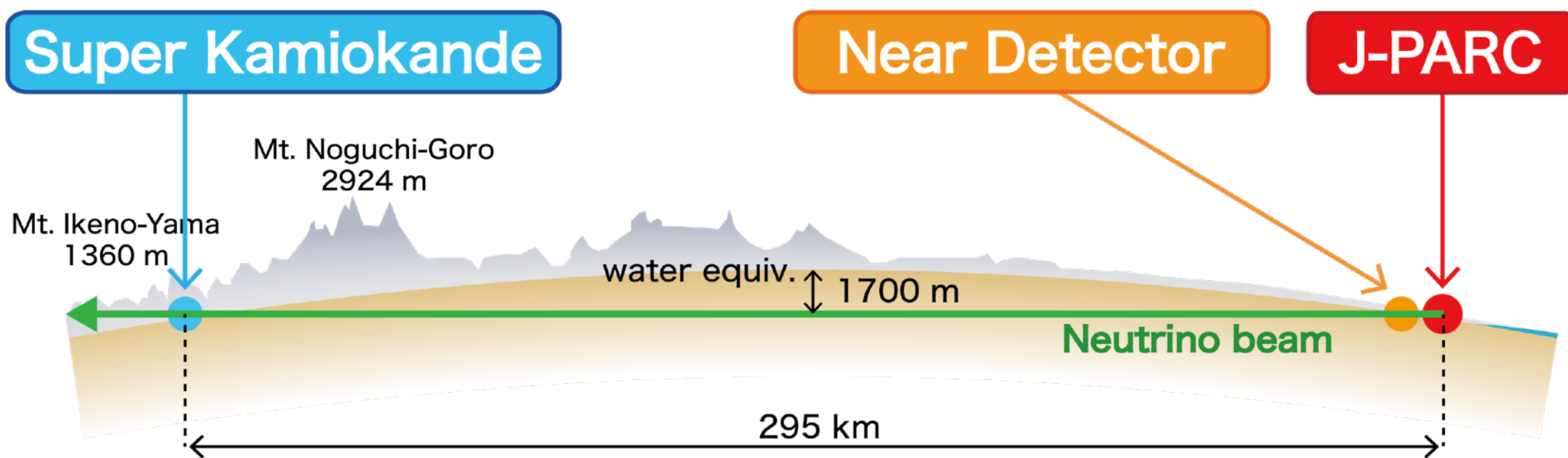

- Recent T2K run had stable beam operation at 900 kW - now surpassing the original design target of 750 kW
- 1E21 protons on target taken in a single run - a new record!
- Several 1 MW beam shots on neutrino target
- Approaching the 1.3 MW target for Hyper-K
- T2K continues to lead the way in neutrino cross-section measurements
- 4 new results published since last May
- First data from ND280 upgrade shown
- CCinclusive selection almost finalised for reco-level data-MC comparisons to be shown publicly
- Exclusive channel selections (CC0pi, CC0pi1p, CC1pi) maturing rapidly
- Also lots of exciting work with neutron tagging

MR Run#	93
MR Shot#	4658948 (2026/03/21 13:55:04)
NU Run#	930611
Event#	31521
Spill#	6428702
Deliv. p# (this J-PARC run)	1.00001e+21
Deliv. p# (2010/Jan/1~)	5.61406e+21

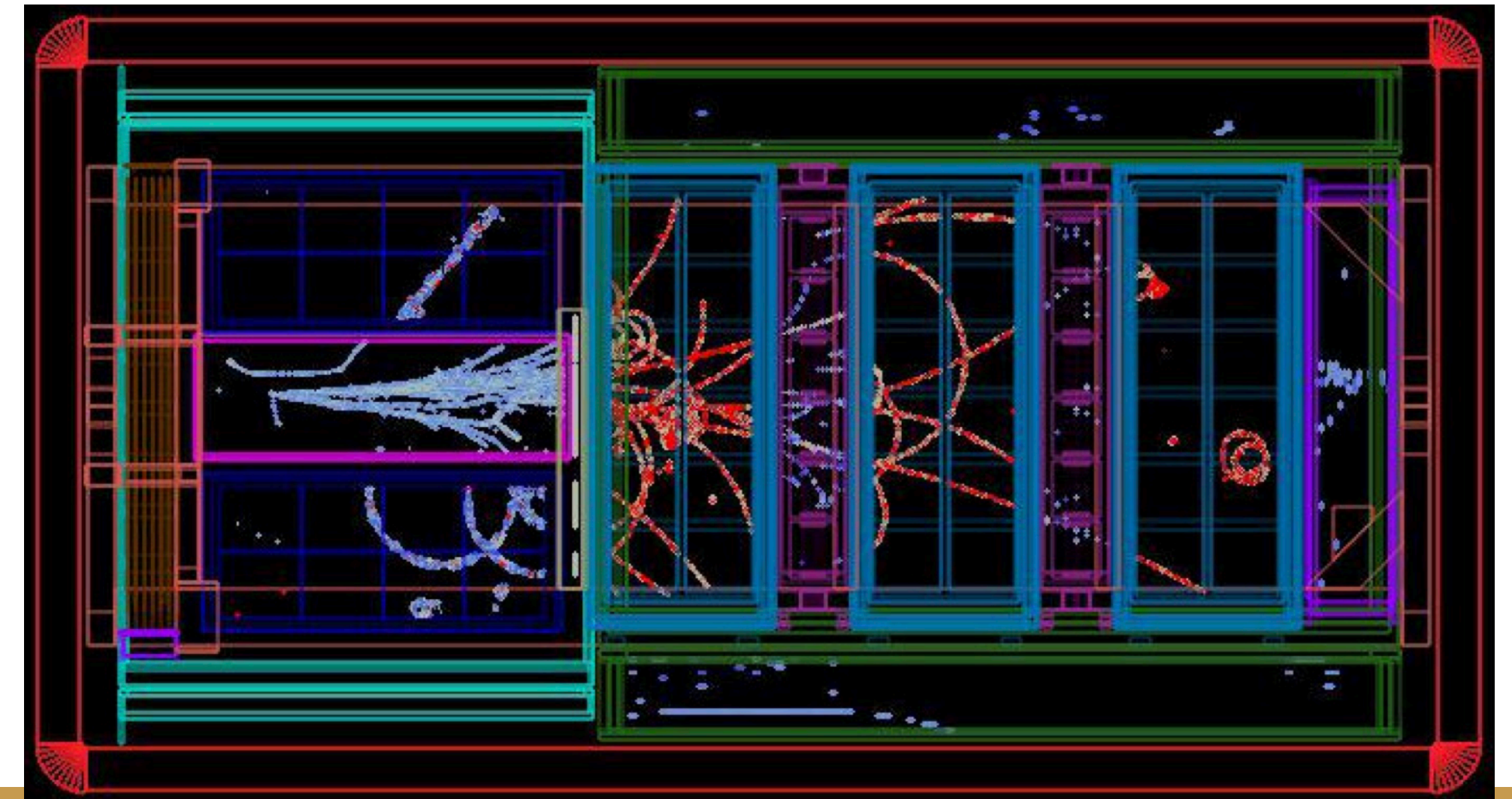

T2K-NOvA analysis published

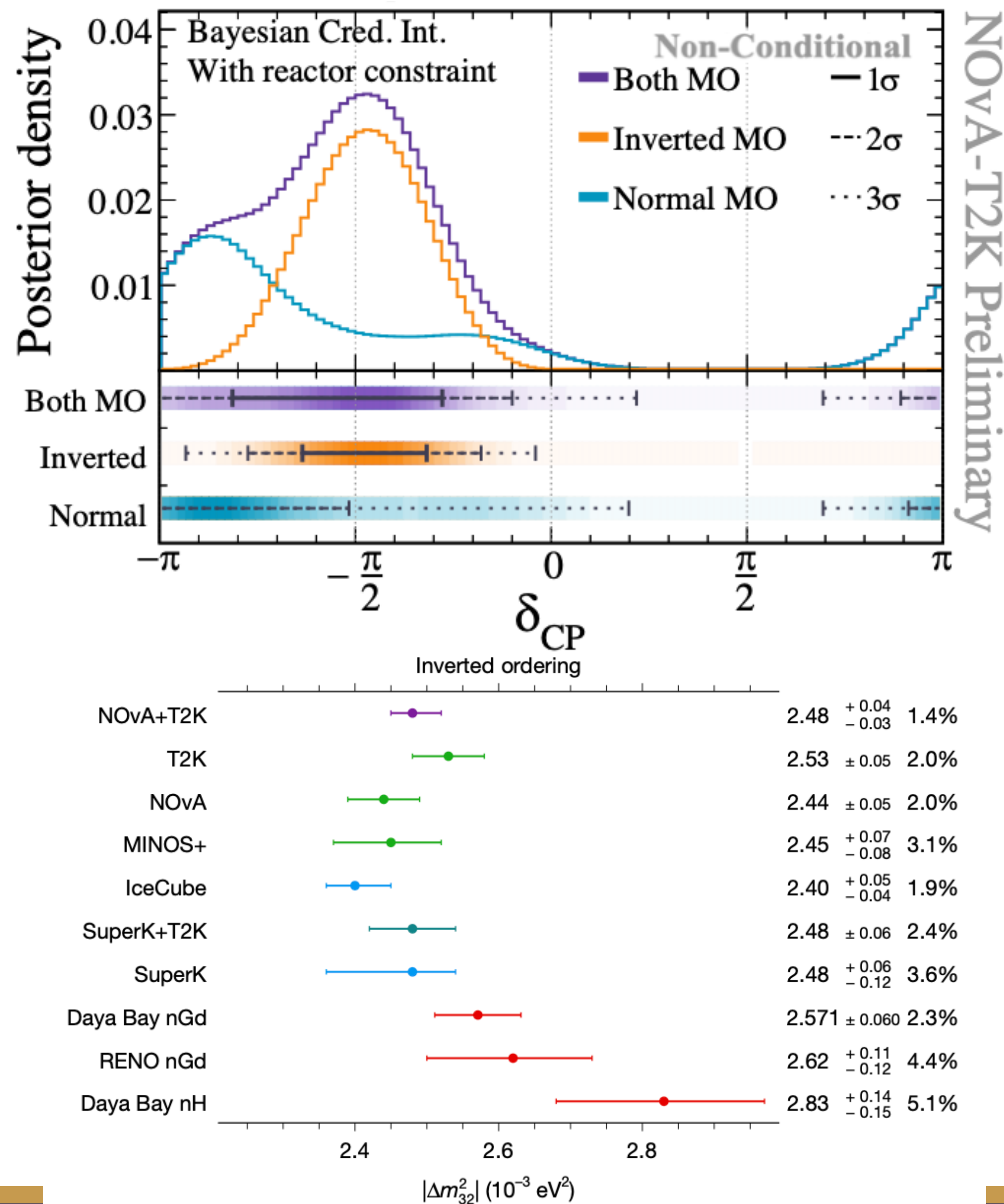

- Analysis now published in [Nature!](#)
- First full combination of two long-baseline experiments
- NOvA has complementary beam with $E_\nu \sim 2$ GeV and 810 km baseline
- T2K has higher sensitivity to δ_{CP} , while NOvA has better sensitivity to matter effects
- Probing both spaces helps to lift degeneracies
- Small preference for IO, while experiments separately prefer NO
- 3σ exclusion of CP conservation in IO, inconclusive for NO
- Most precise measurement of $|\Delta m_{32}^2|$ so far!
- Follow-up analyses in the works

ND280 analysis

- 👤 ND280 stably running with upgrade configuration
- 👤 Ellen was developing a CC0pi2p selection for comparison between generator models
- 👤 Short track reconstruction in SFGD gives better sensitivity to nucleon effects such as 2p2h and FSI
- 👤 Good improvements made to the selection, achieving $\epsilon=21.5\%$, $\rho=73\%$
- 👤 Work to be continued by another analyser

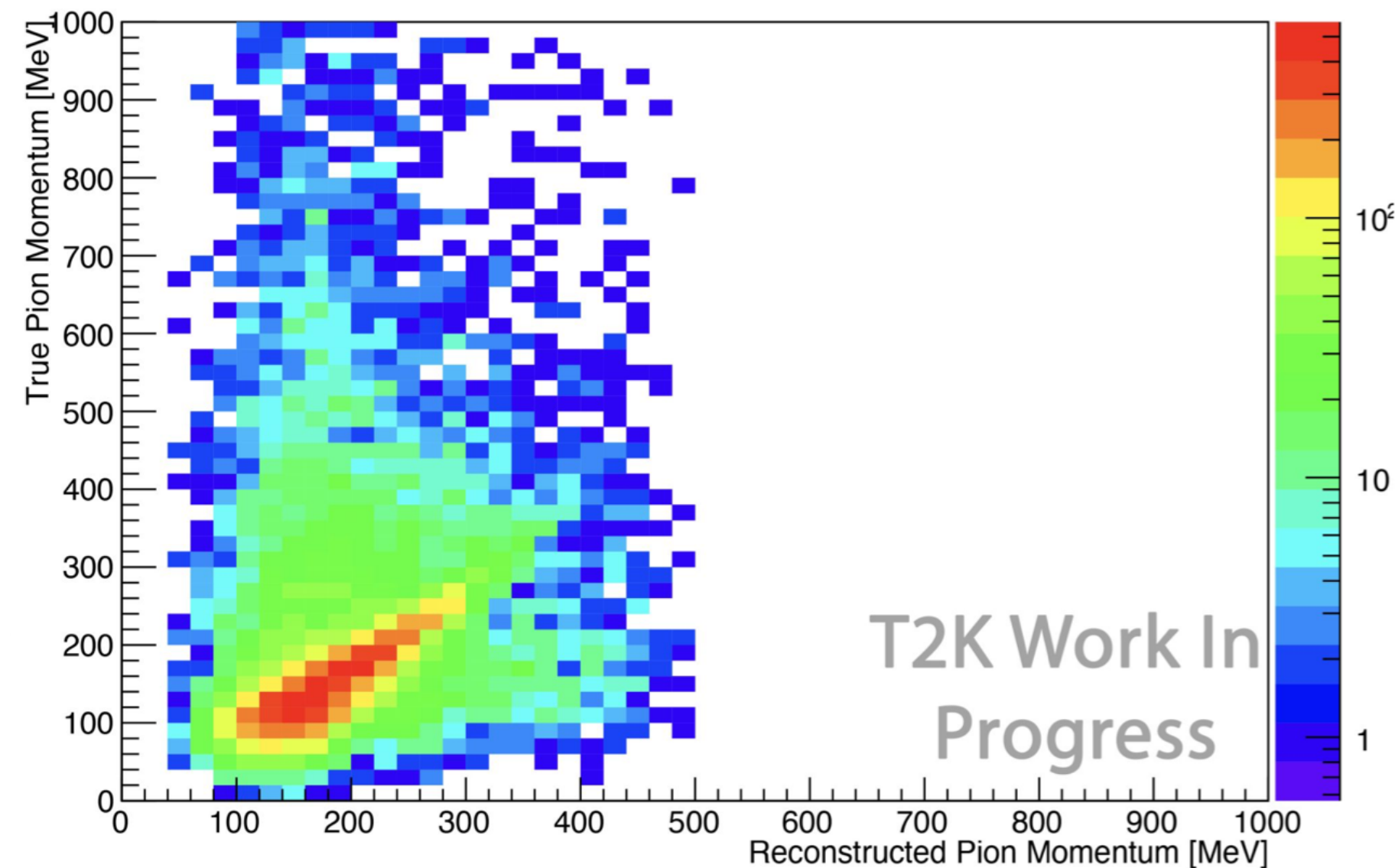
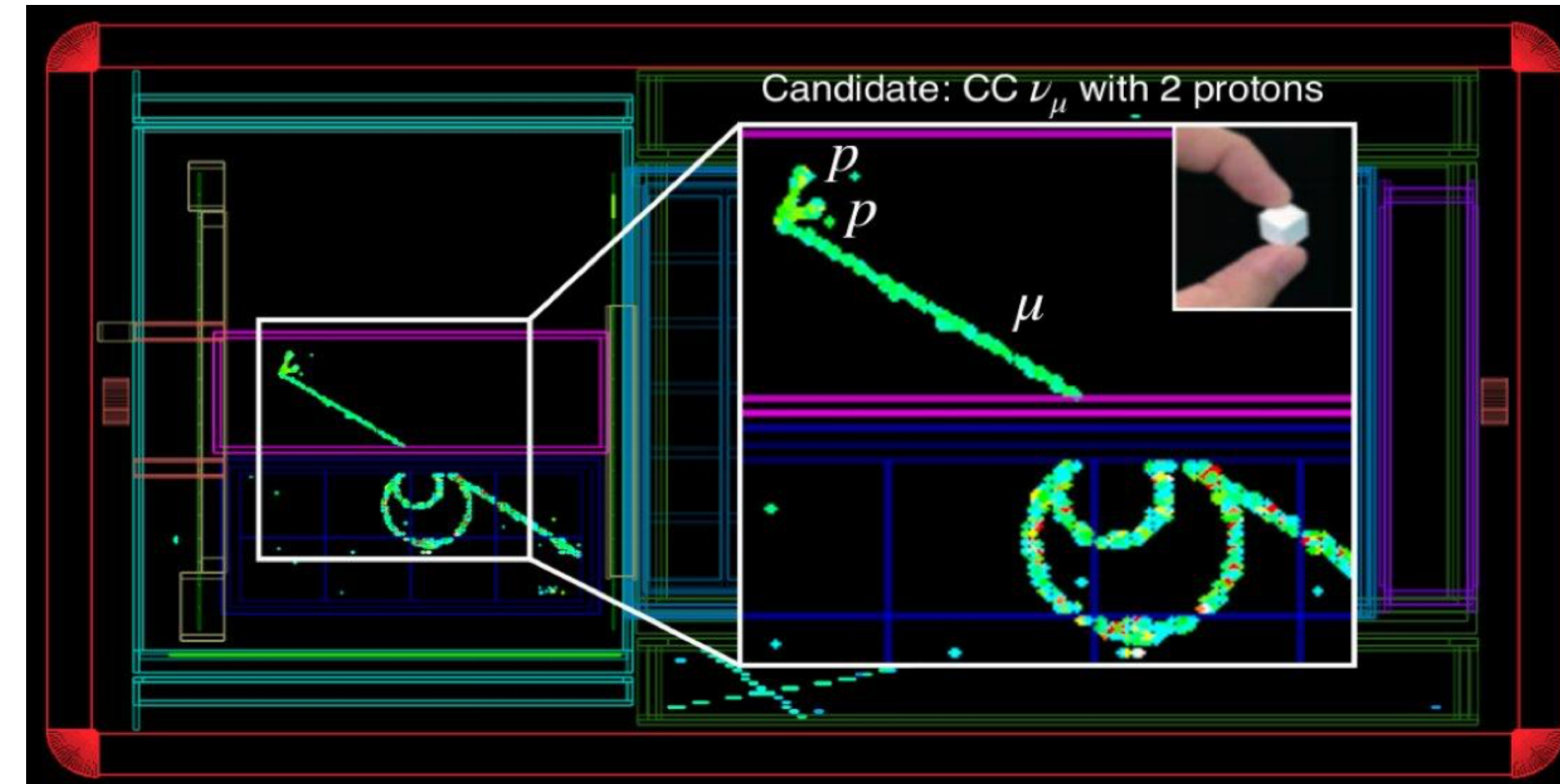

- 👤 Sam and Joe are both ND280 CC1pi group convenors, as well as in the task force investigating CC1pi excess in far detector data
- 👤 Looking at Michel electron-tagged pions as part of the near detector constraint
- 👤 Sam is also a convenor of the cross-section group

Global PID for ND280



- Patrick is working on a global PID tool for ND280 analyses using BDTs
- Trained with particle gun info
- Performance in 'classic' ND280 configuration obtained good separation for positrons and protons, worse for muon and pion
- Now working to extend this to the upgrade using variables from the new sub-detectors
- Will repeat N-1 studies for combined set of variables
- Then apply to a CC1pi selection, comparing to the standard selection

Probability of proton event

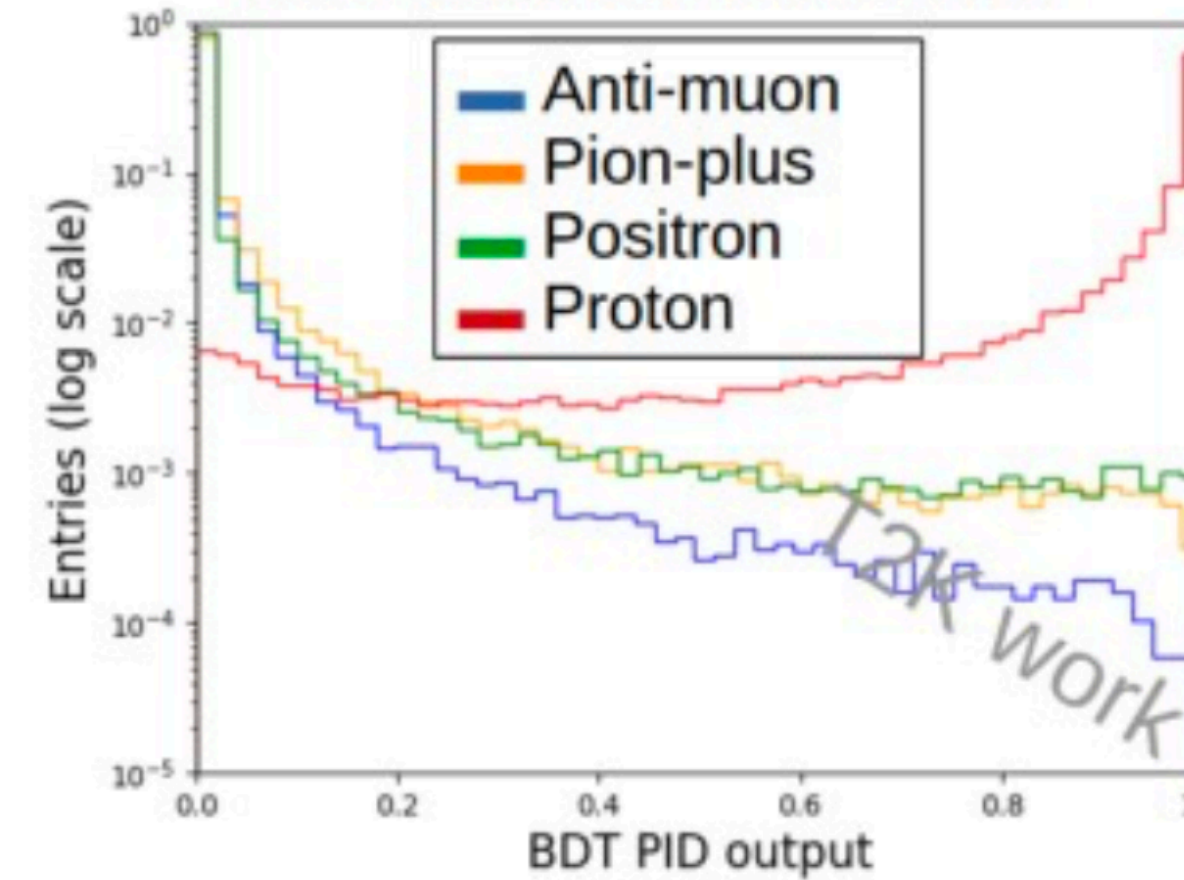

Probability of muon event

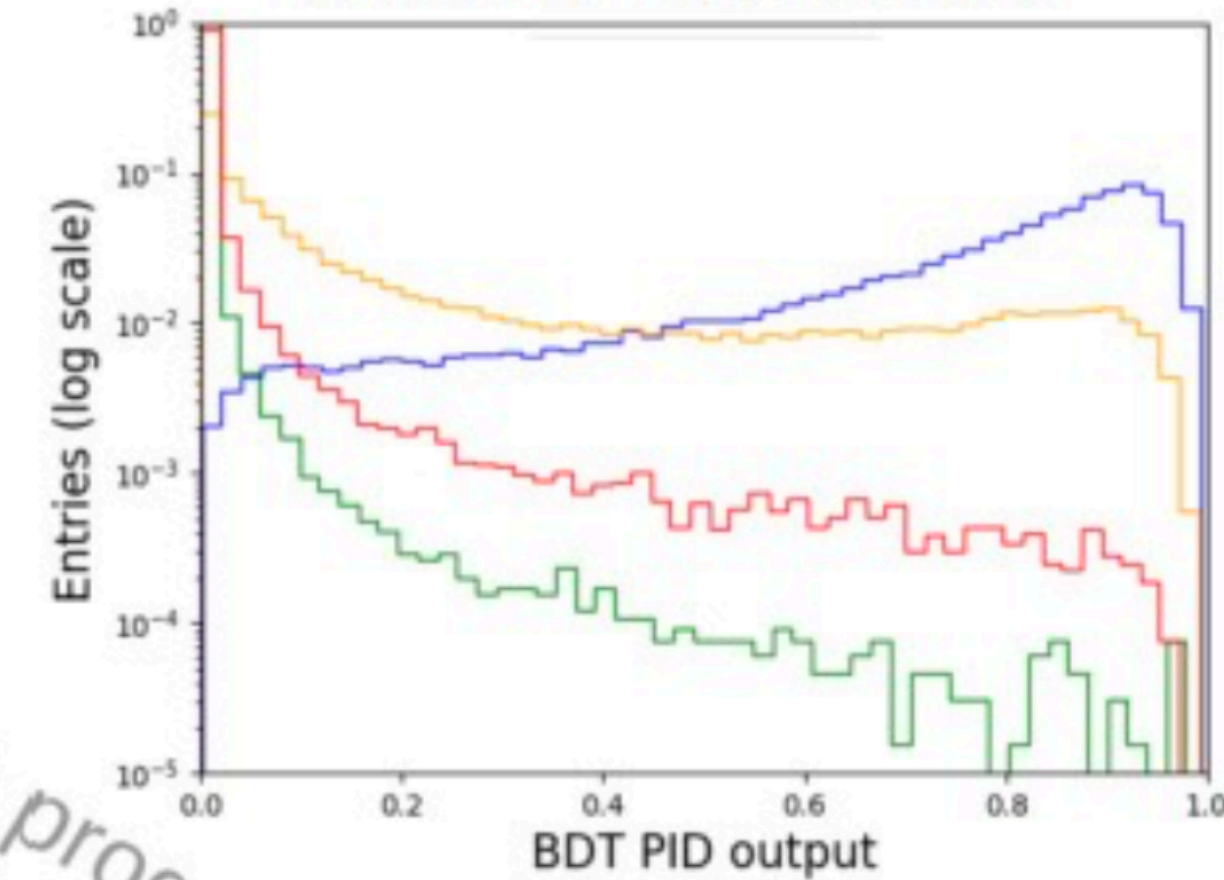

Probability of positron event

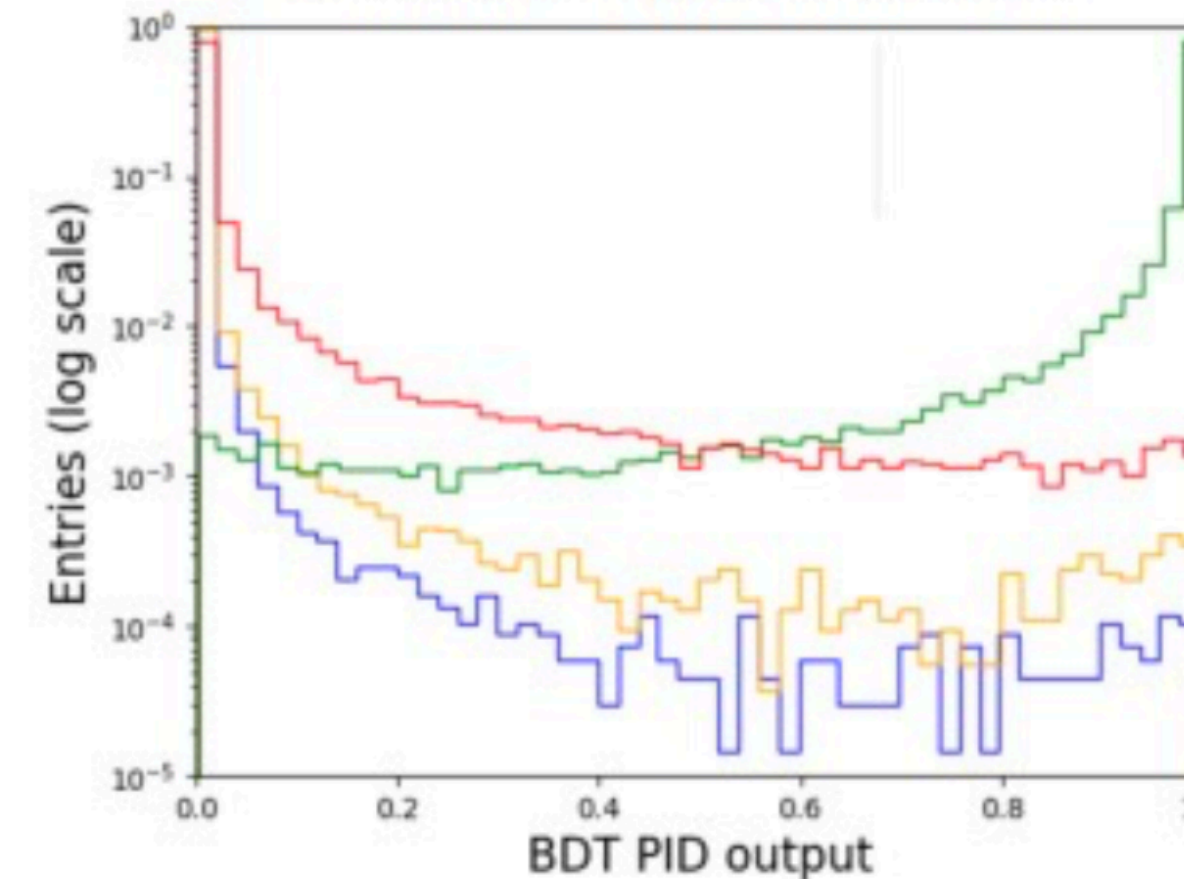

Probability of pion event

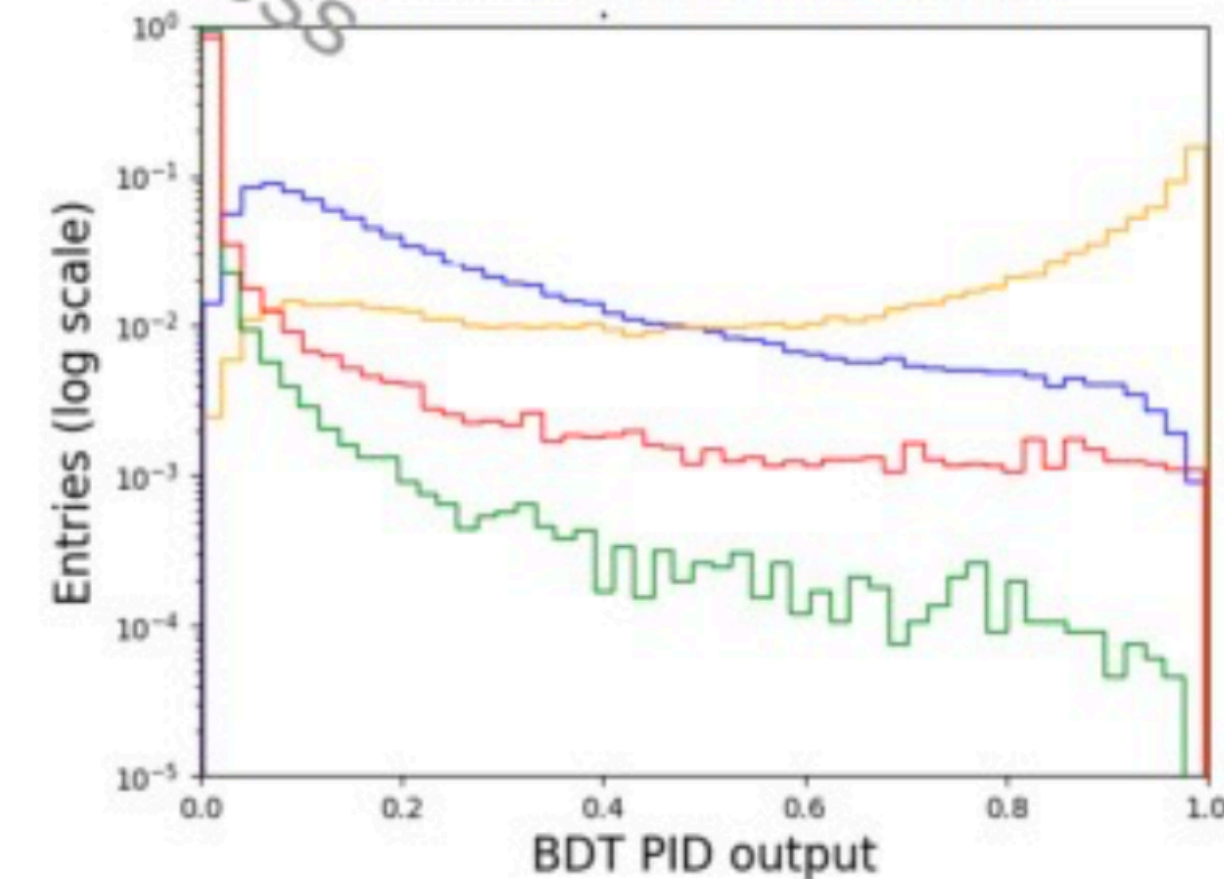

Super-Kamiokande



- 🧑 30th anniversary of SK operation (start of SK-I Run #001000) on 1st April 2026 🎉
- 🧑 Several papers published in the last year, including [DSNB result](#) accepted by AAS ApJ
- 🧑 UK light injection system used to monitor detector water quality
- 🧑 Sam and Neil report weekly at the SK steering committee meetings
- 🧑 Charge ratio of near and far regions in top diffuser beam spot shows high sensitivity to changes in water quality at the level of $\sim 0.2\%$

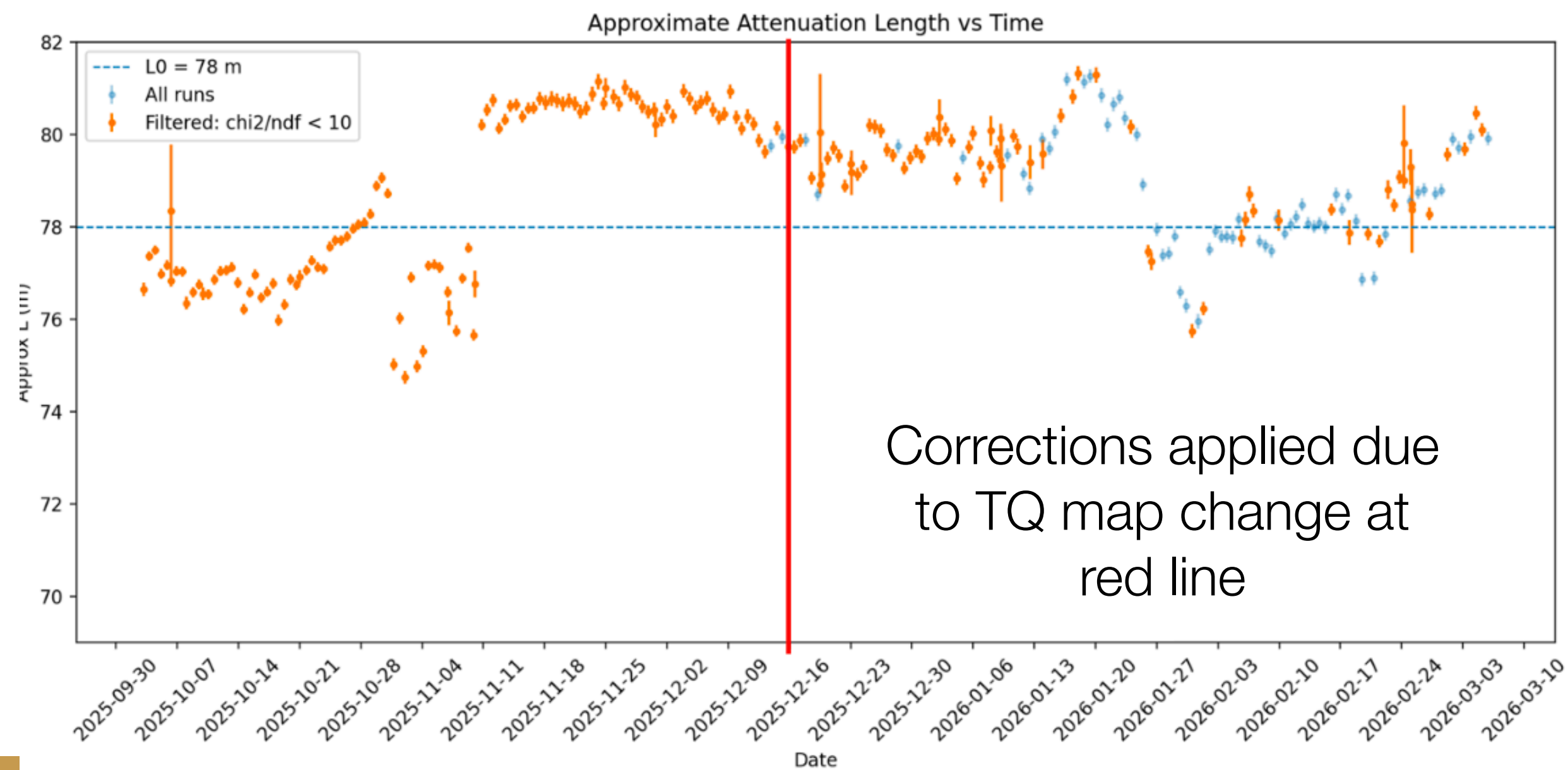
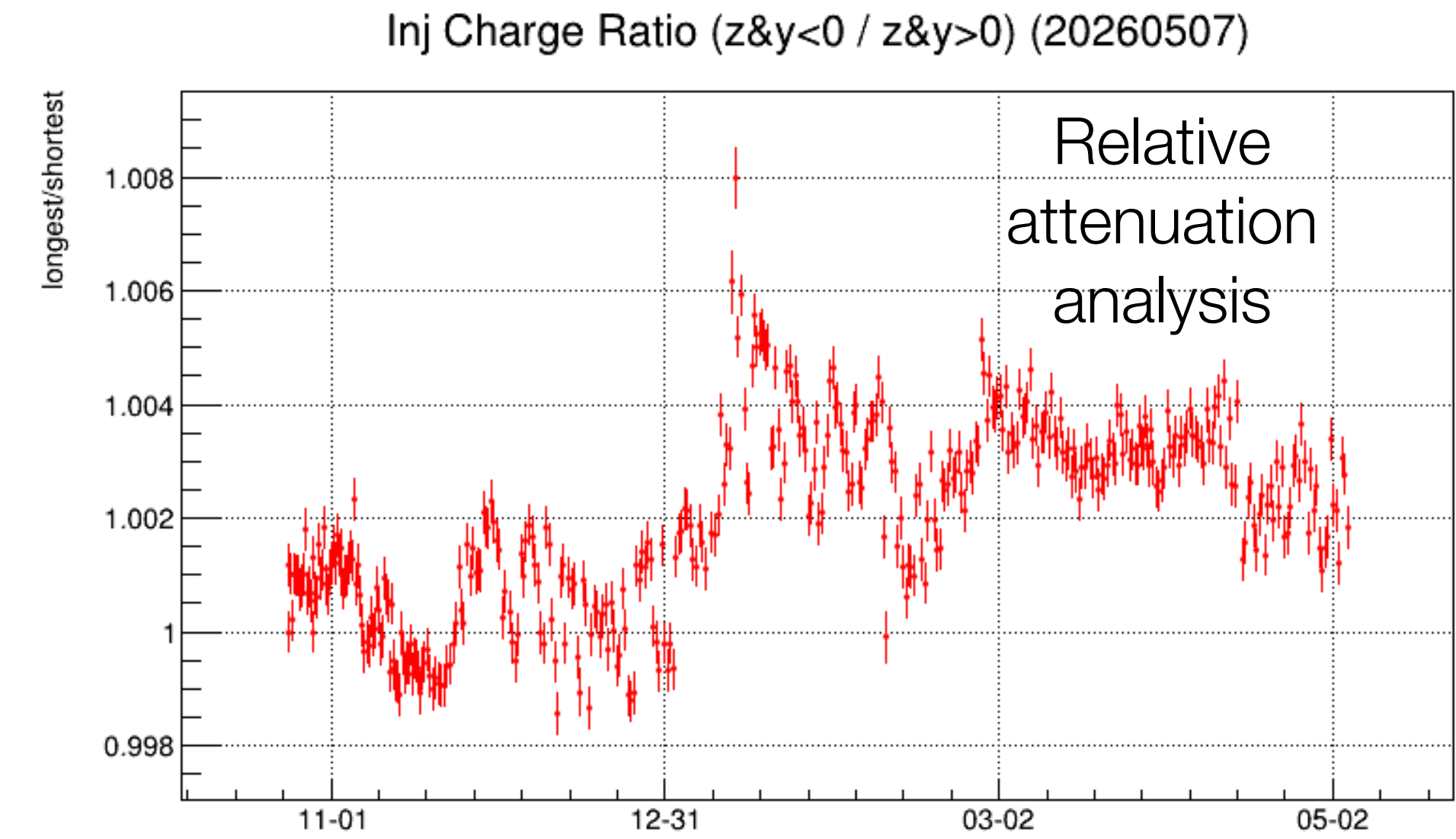

- 🧑 Unik has been extending Adam's attenuation analysis work:
- 🧑 Exponential fit to ratio of charge against reference period vs distance
- 🧑 Currently working on corrections to make tracking of attenuation length robust against changes such as calibration constants

Super-Kamiokande

- 30th anniversary April 2026 🎉
- Several papers accepted by APS
- UK light injection by Sam and Neill
- Charge ratio of high sensitivity

/ z&y>0) (20260507)

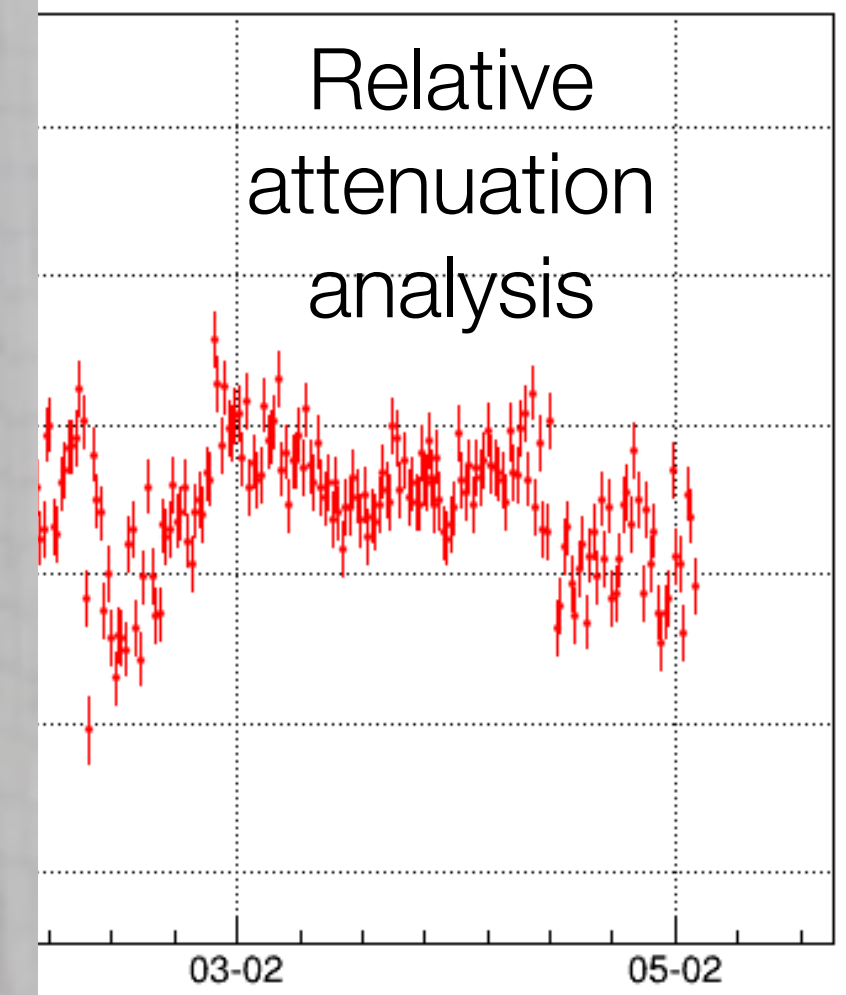

uation analysis

ainst reference

ake tracking of ges such as

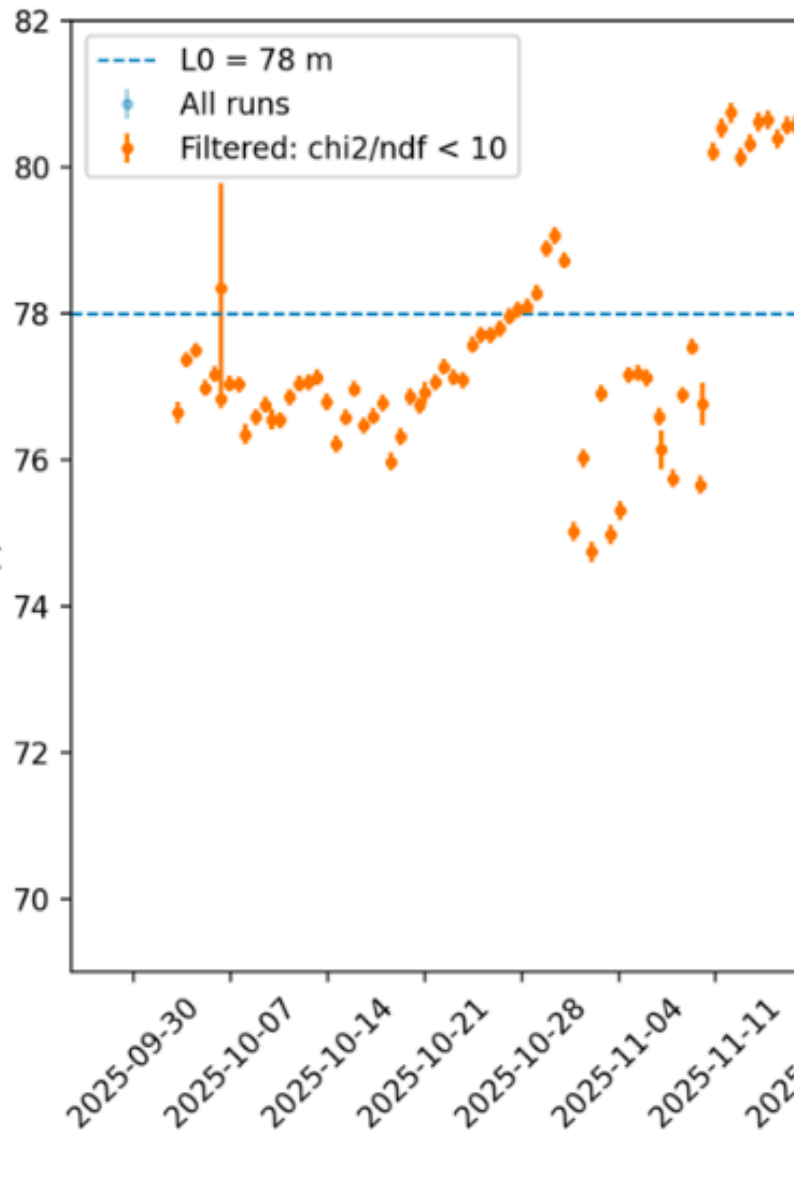
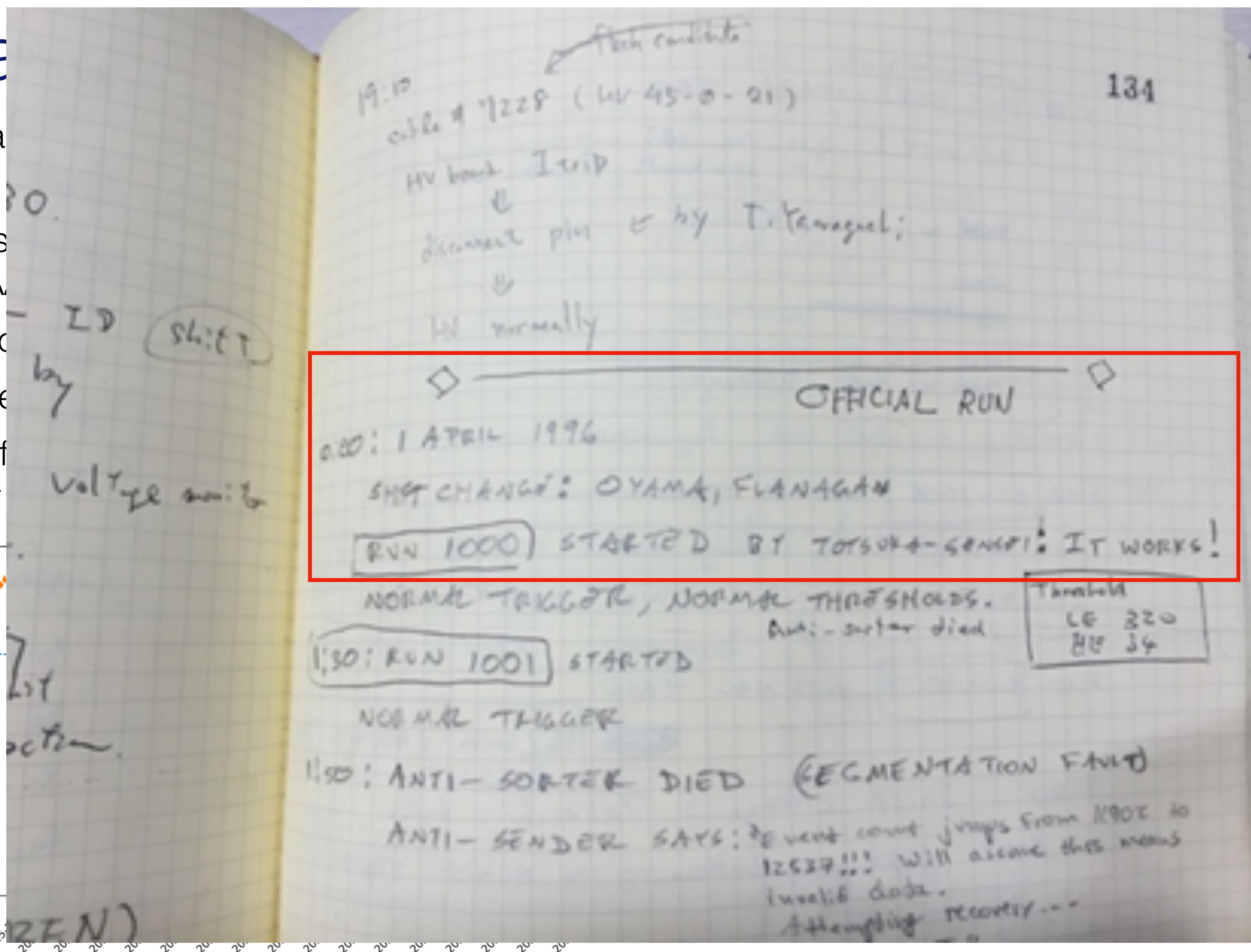

Hyper-Kamiokande

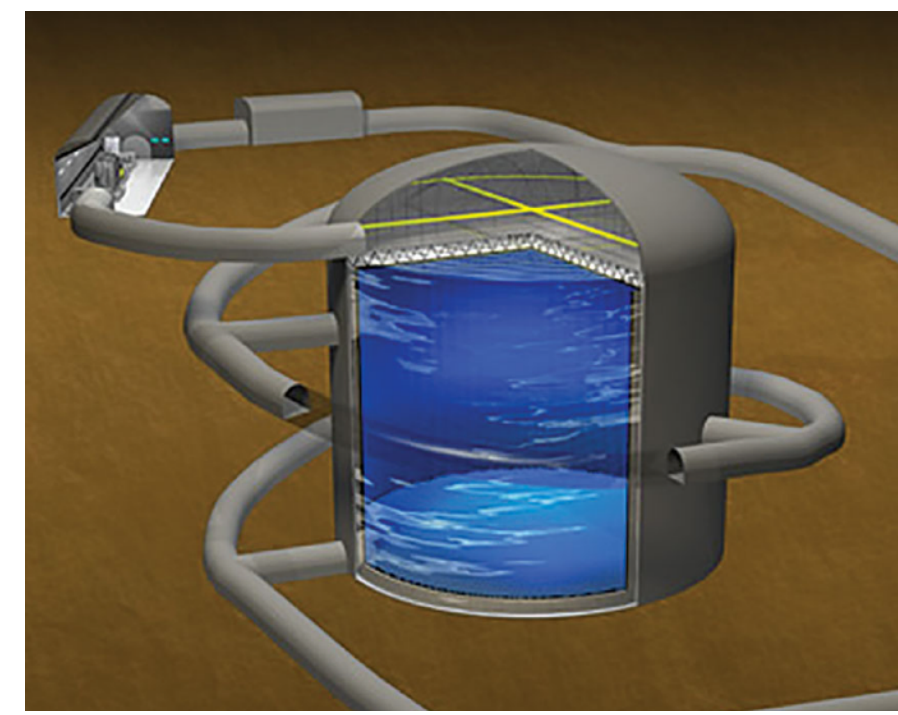

- 👤 258 kton volume water Cherenkov detector
- 👤 216 kton inner detector (~187 kton fiducial volume)
- 👤 1 m thick outer detector used as a veto region
- 👤 Instrumented with 20,000 50cm PMTs (ID), plus multiPMTs and 8cm PMTs (OD)
- 👤 Broad physics program including:
 - 👤 Neutrino oscillation measurements (CP violation, mass hierarchy, θ_{23} octant)
 - 👤 Atmospheric and solar neutrinos
 - 👤 Supernova relic neutrinos
 - 👤 Proton decay

'Sensitivity of the Hyper-Kamiokande experiment to neutrino oscillation parameters using accelerator neutrinos' recently published in EPJC - [link](#)

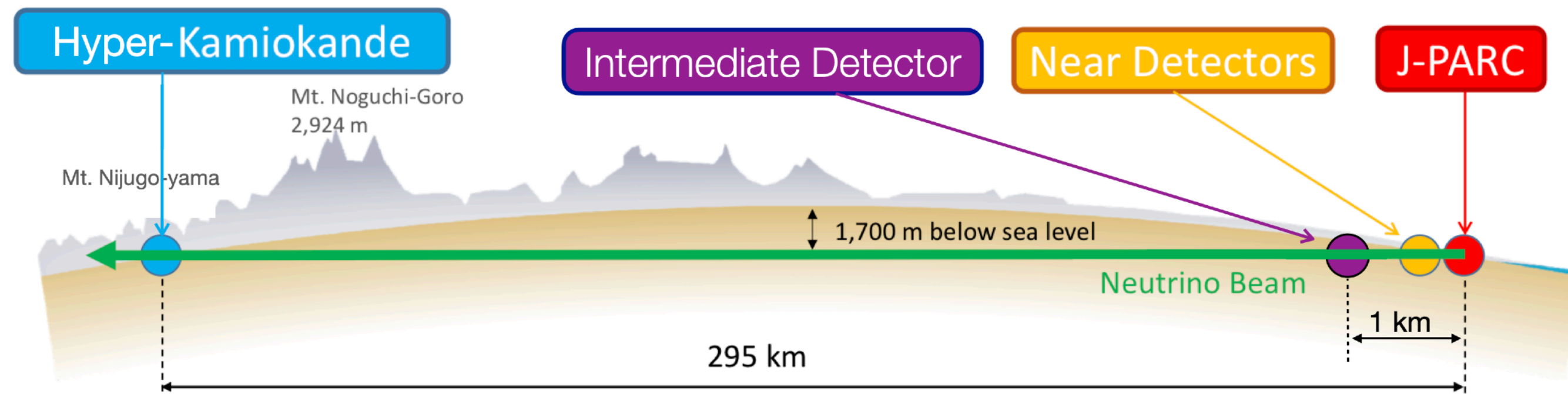
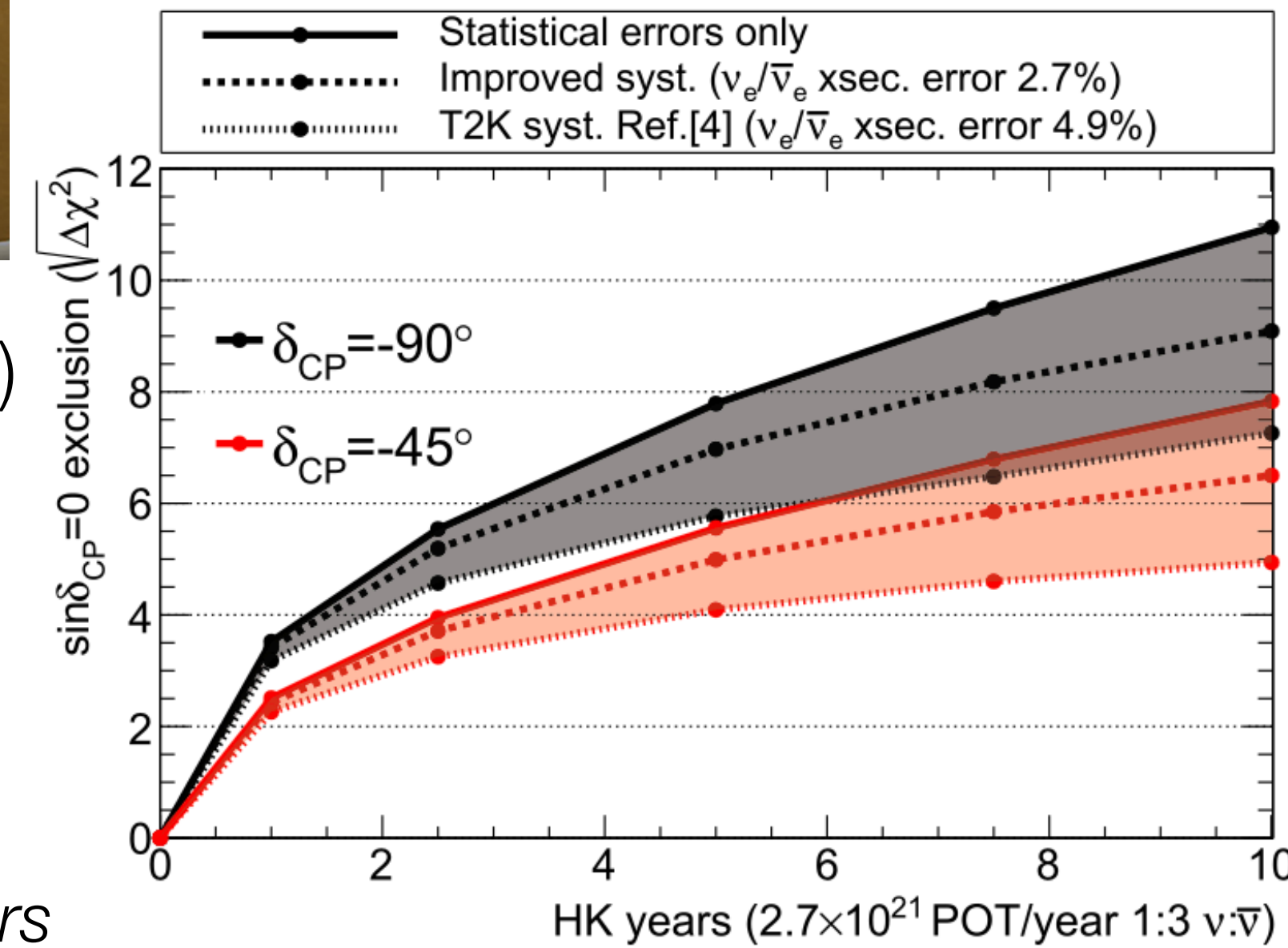

multiPMTs provide increased spatial and timing resolution



Systematics and calibration



- 👤 Detector systematics can limit our sensitivities and even mimic oscillation effects
- 👤 Systematic effects must be controlled to sub-1% level
- 👤 Requires an extensive calibration program and improved strategies
- 👤 Bottom-up calibration approach seeks to quantify uncertainties on reconstructed quantities
- 👤 Unik has been investigating how changes in detector parameters affect reconstructed quantities
- 👤 Water optical properties
- 👤 Optical surface effects
- 👤 PMT response
- 👤 Detector environment
- 👤 Further information in Unik's talk tomorrow!
- 👤 Neil is the HK calibration convenor
- 👤 Overseeing systems from all other countries in addition to our own

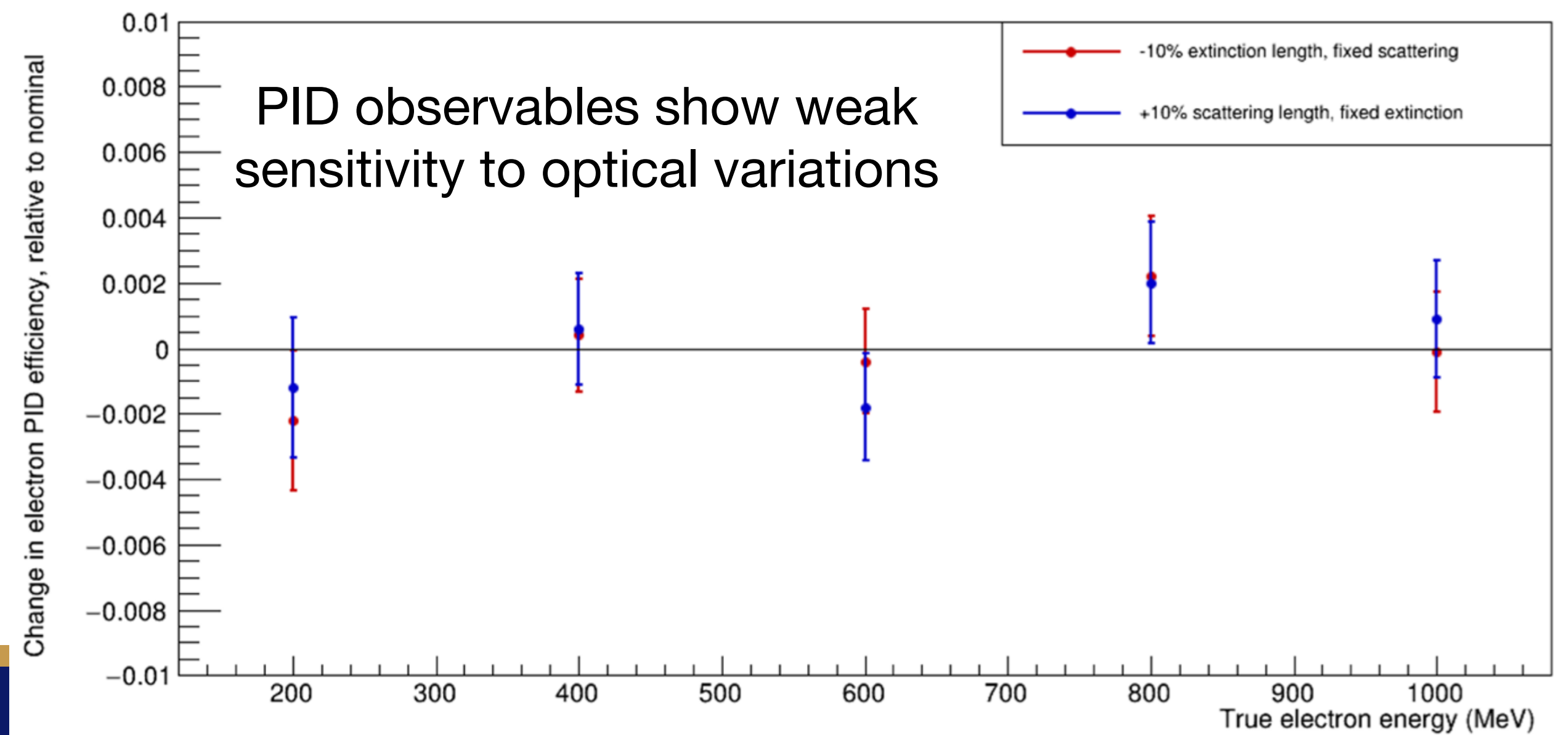
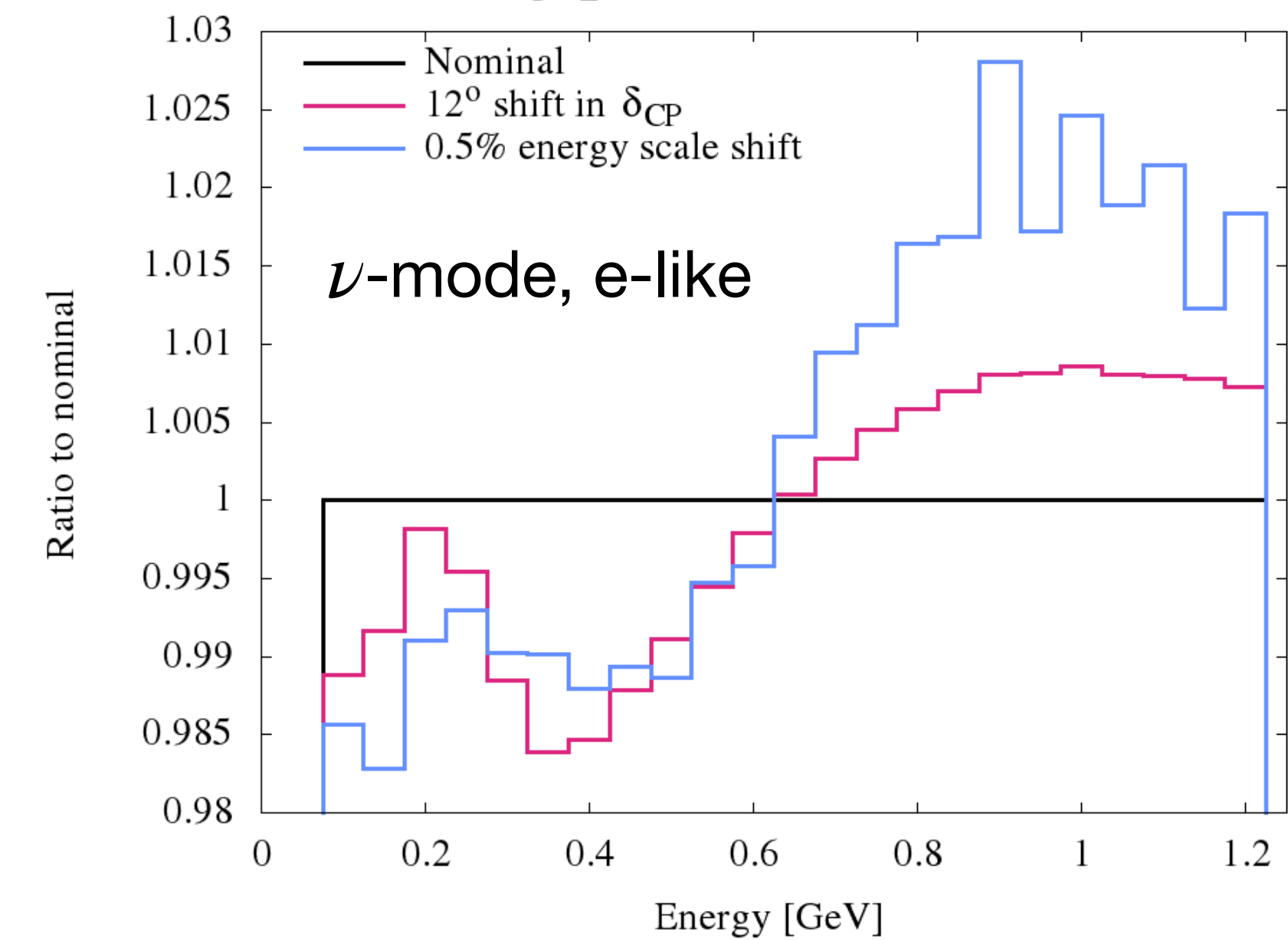

Light injection system



Hyper-Kamiokande

- 👤 UK group (Liverpool, Sheffield, Warwick) developing a light injection calibration system
- 👤 Inner detector - 33 diffusers and collimators illuminated by 6 pulsed lasers
- 👤 Outer detector - 12 collimators illuminated by lasers, and 122 diffusers illuminated by pulsed LED sources
- 👤 Liverpool responsible for light source and optical fibre specification and testing, along with detector integration
- 👤 LED pulser system designed by Balint ready for production
- 👤 Achieved review committee sign-off and collaboration approval for purchase/production
- 👤 Laser has arrived in Japan, fibres in varying states of production, switch on order
- 👤 Balint and Neil are currently in Japan for the start of the QA/QC procedures on the diffusers and collimators

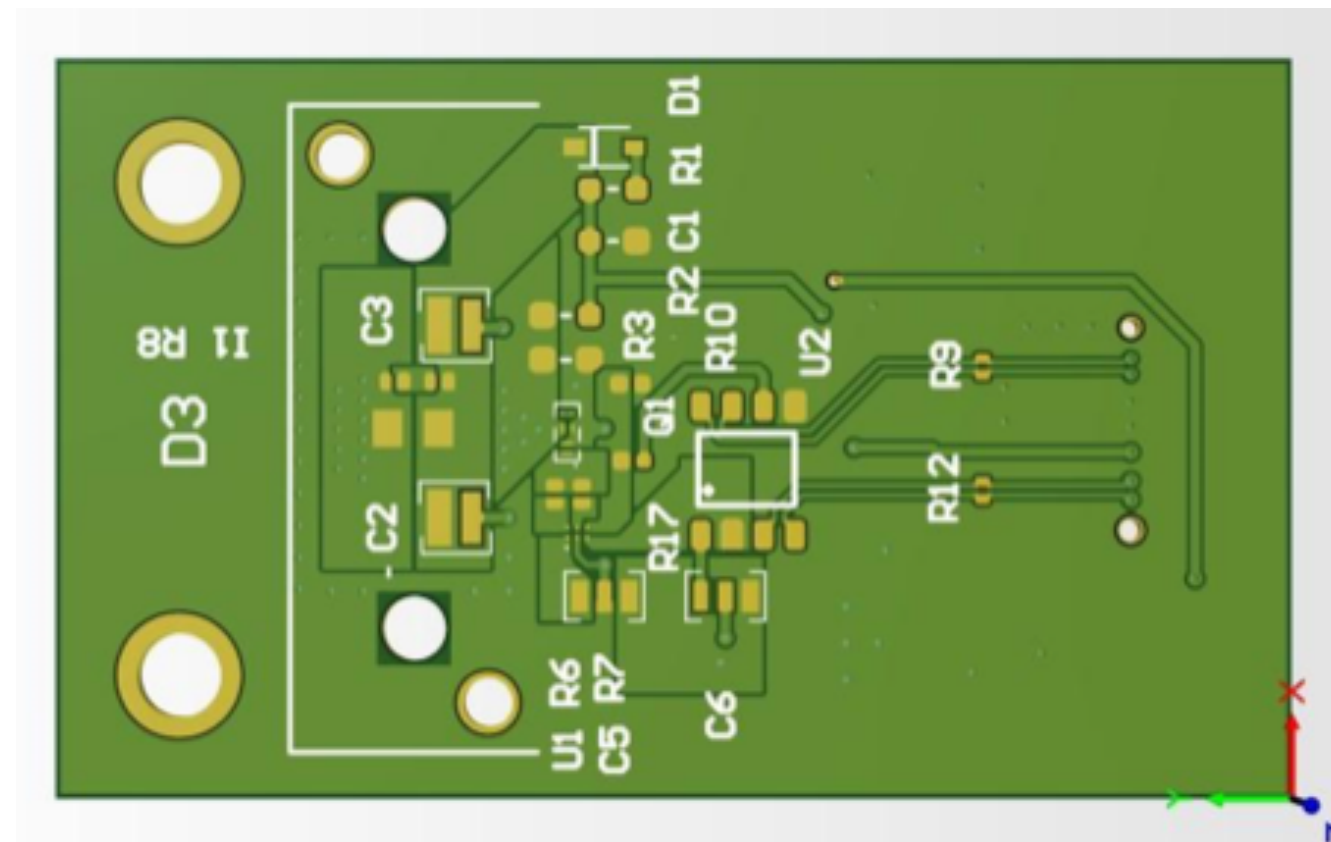
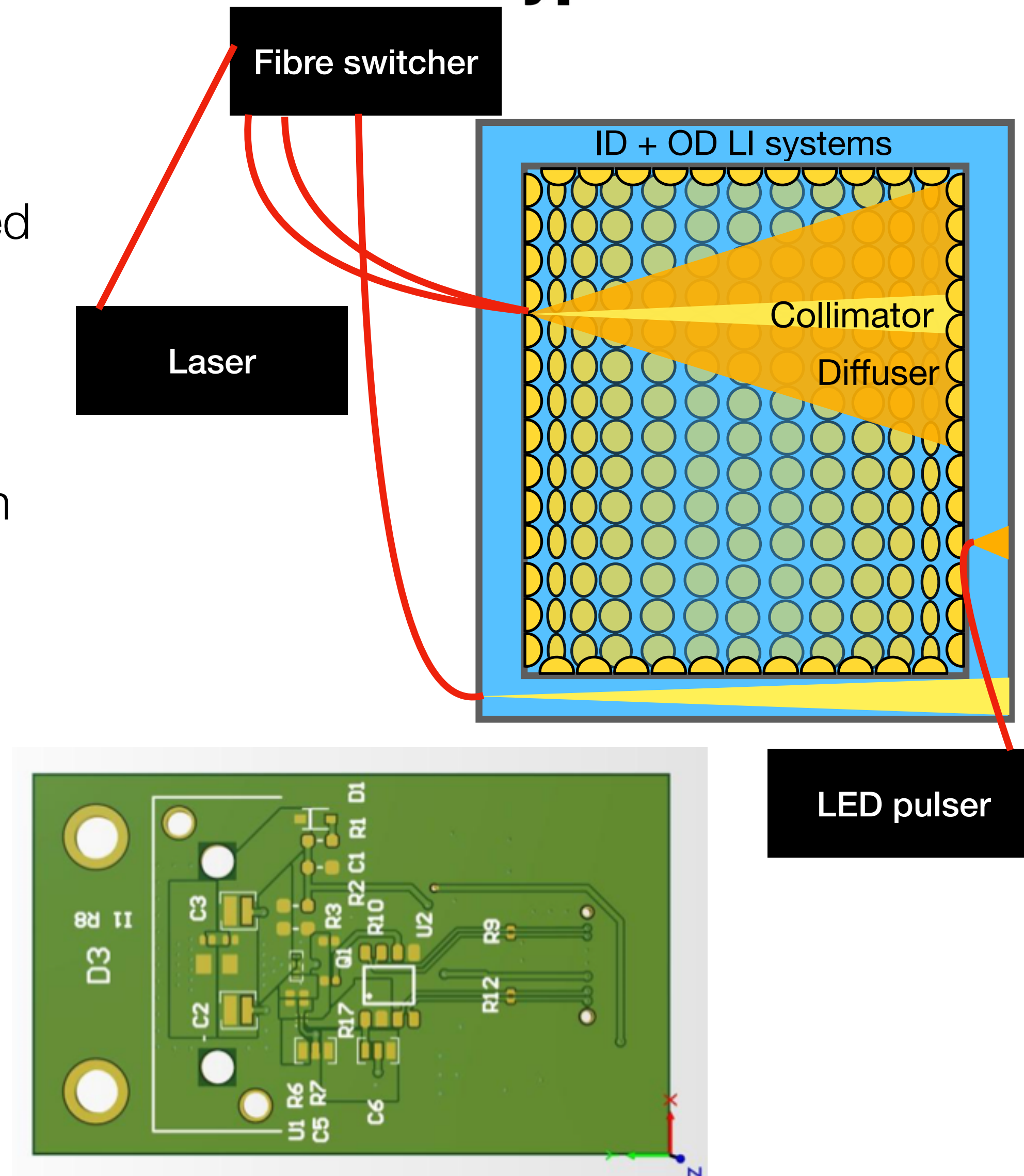

LI analysis

- Naomi has been working on using the diffusers for T_0 calibration
- Characterising photon arrival time for PMTs from overlapping injectors allows us to calibrate out timing offsets

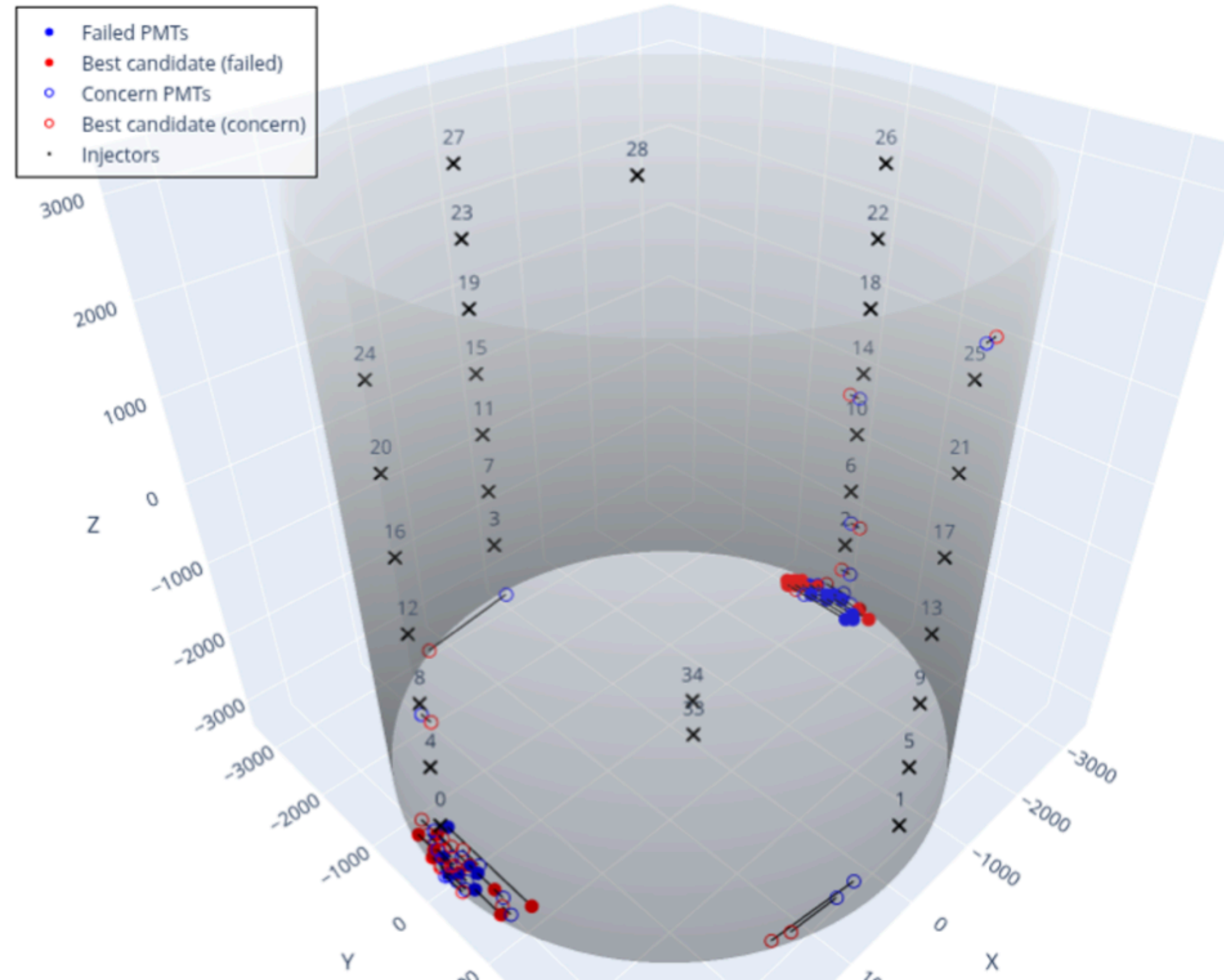
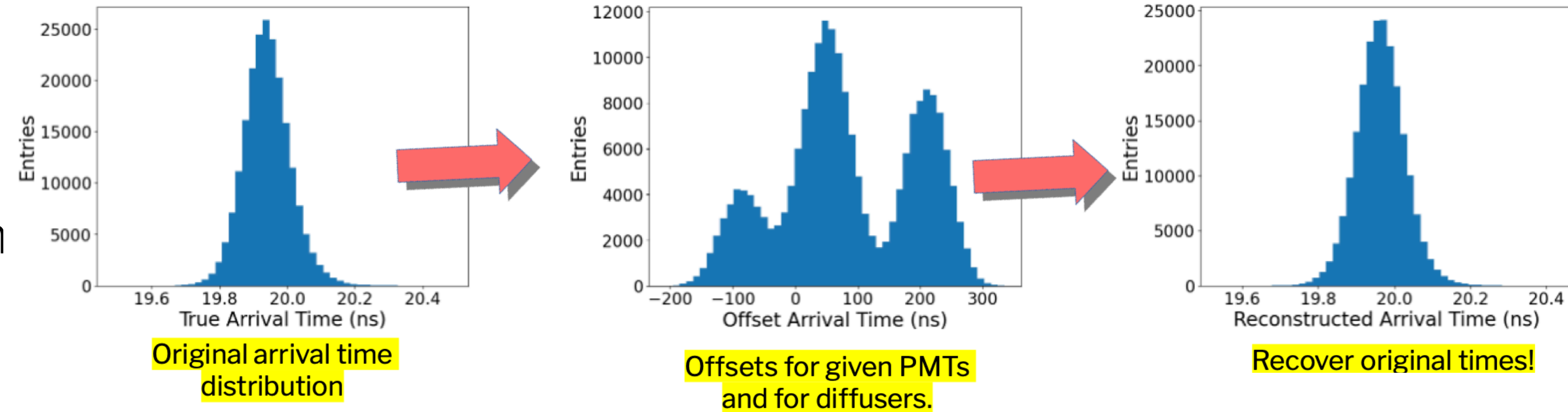

- Can also use timing residuals for PMTs hit by diffuser light to confirm whether PMTs are in the correct position
- Important to identify whether channels have been swapped
- This is a realistic concern in a detector with 20,000 PMTs
- This works for over 99% of PMTs
- Naomi is also working on machine learning methods for reconstruction - see her talk for details!

Installation planning

- 👷 Lots of work on LI installation logistics as construction is rapidly approaching
- 👷 Planning fibre routing, installation procedures, logistics with other far detector groups
- 👷 Fibres will be installed from a small gondola suspended up to 70m high
- 👷 Conducted claustrophobia testing using the gondola mockup in the workshop basement
- 👷 Liverpool and external researchers
- 👷 Thanks to Mark and the workshop for accommodating us with this!

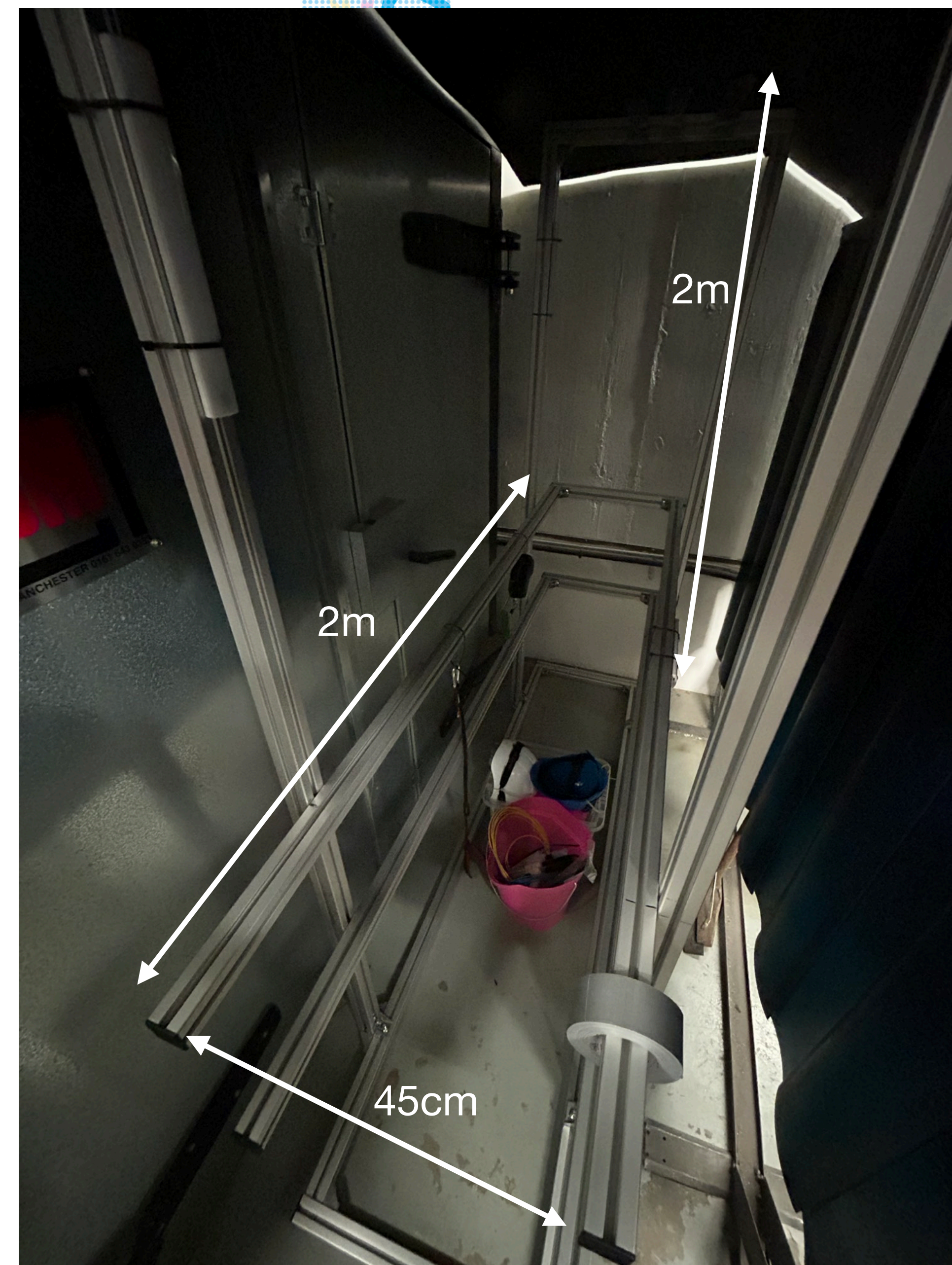
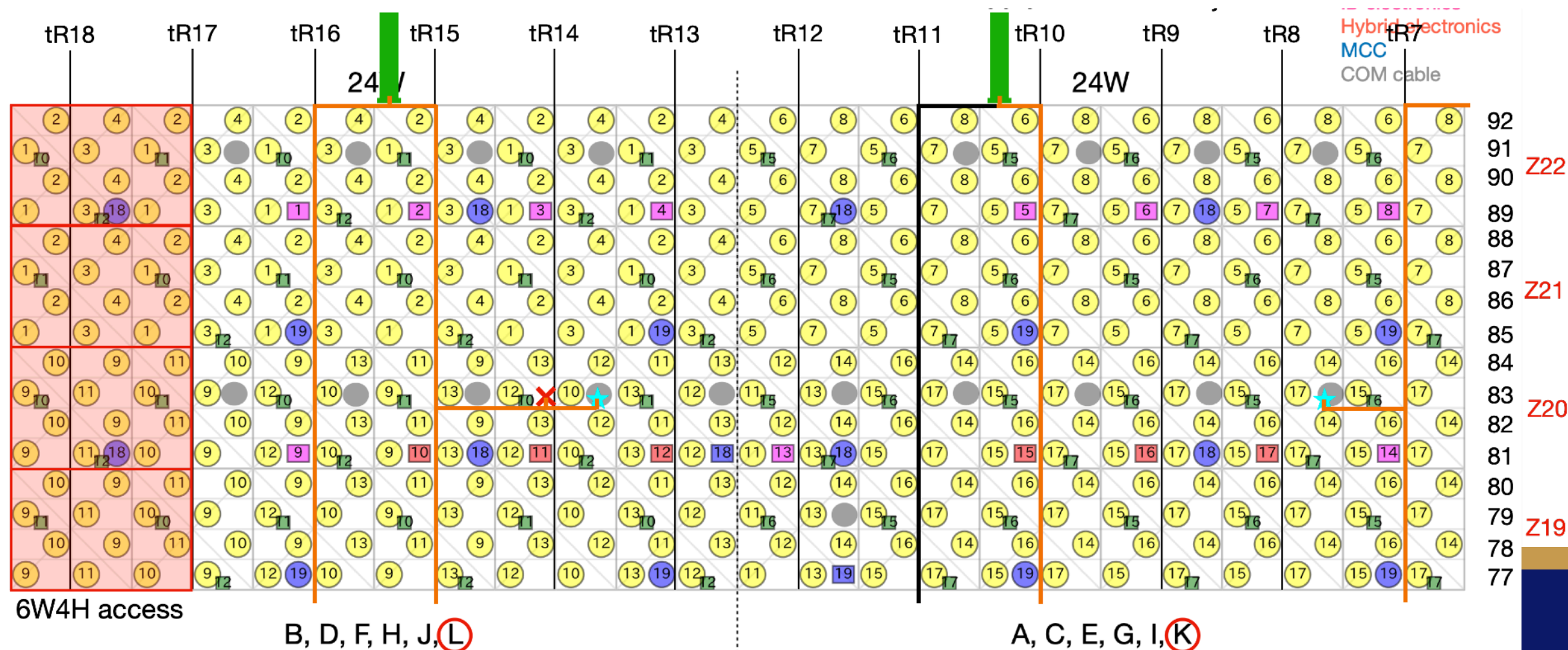

Construction status

- 👷 Cavern excavation completed last summer
- 👷 Largest underground man-made structure in the world
- 👷 2/3s of the stainless steel lining installed, now reaching 48m height
- 👷 19343 PMTs delivered
- 👷 Full scale construction to begin with dome in September, installation shifts start from January onwards
- 👷 On track to begin operation in JFY2028
- 👷 Follow the progress on the Kamioka Observatory instagram account!



@KAMIOKA OBS_PR

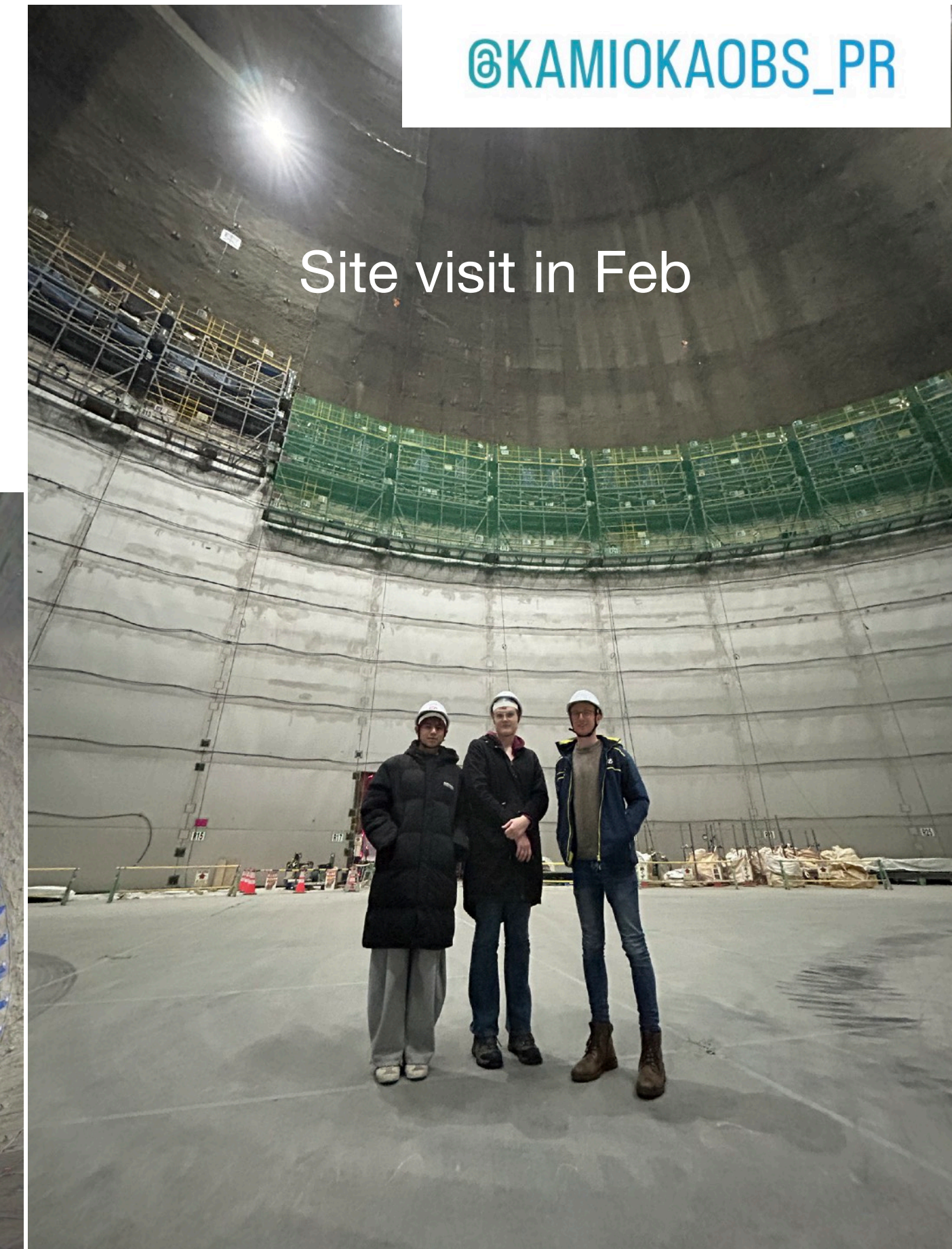

Site visit in Feb

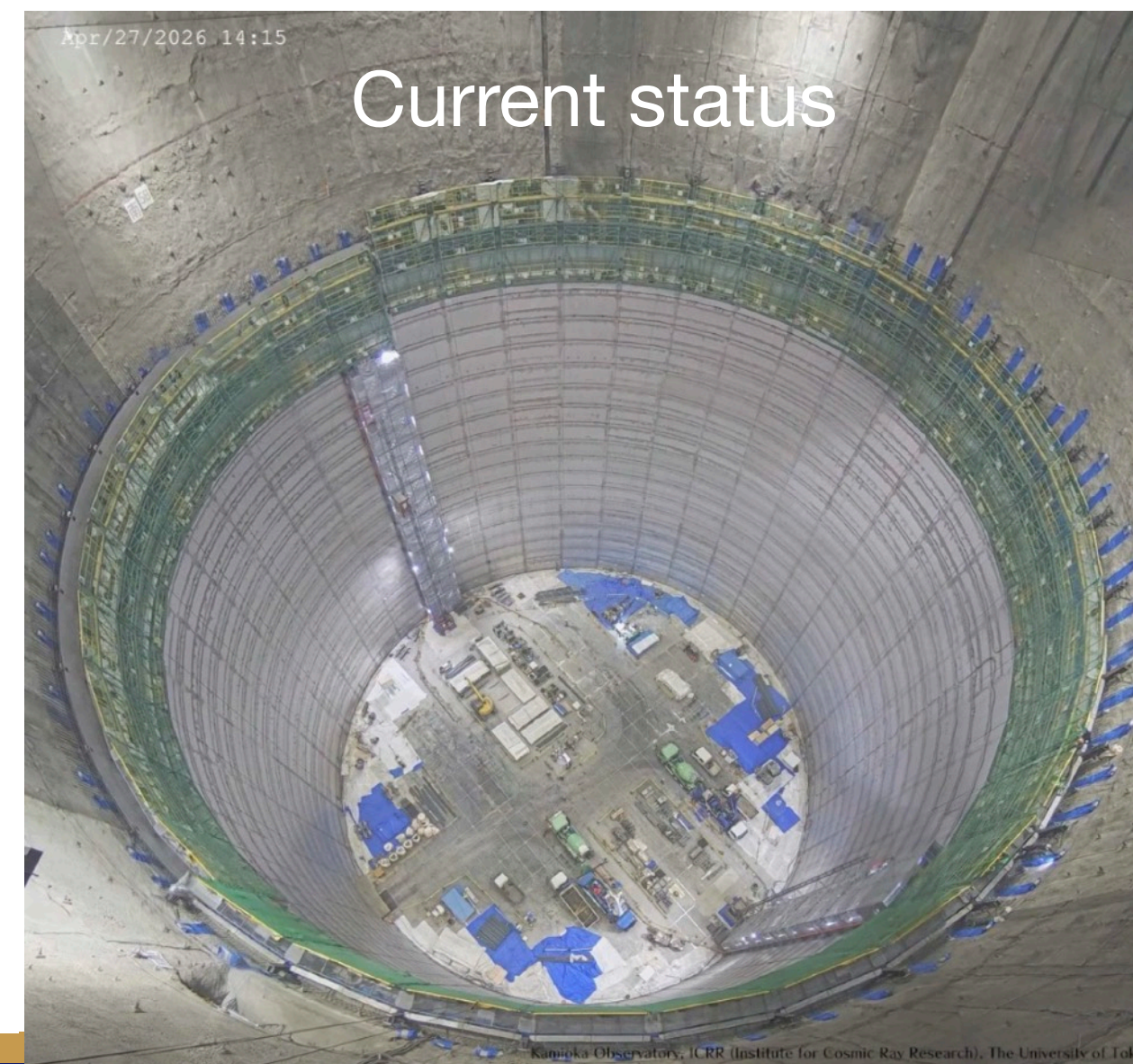
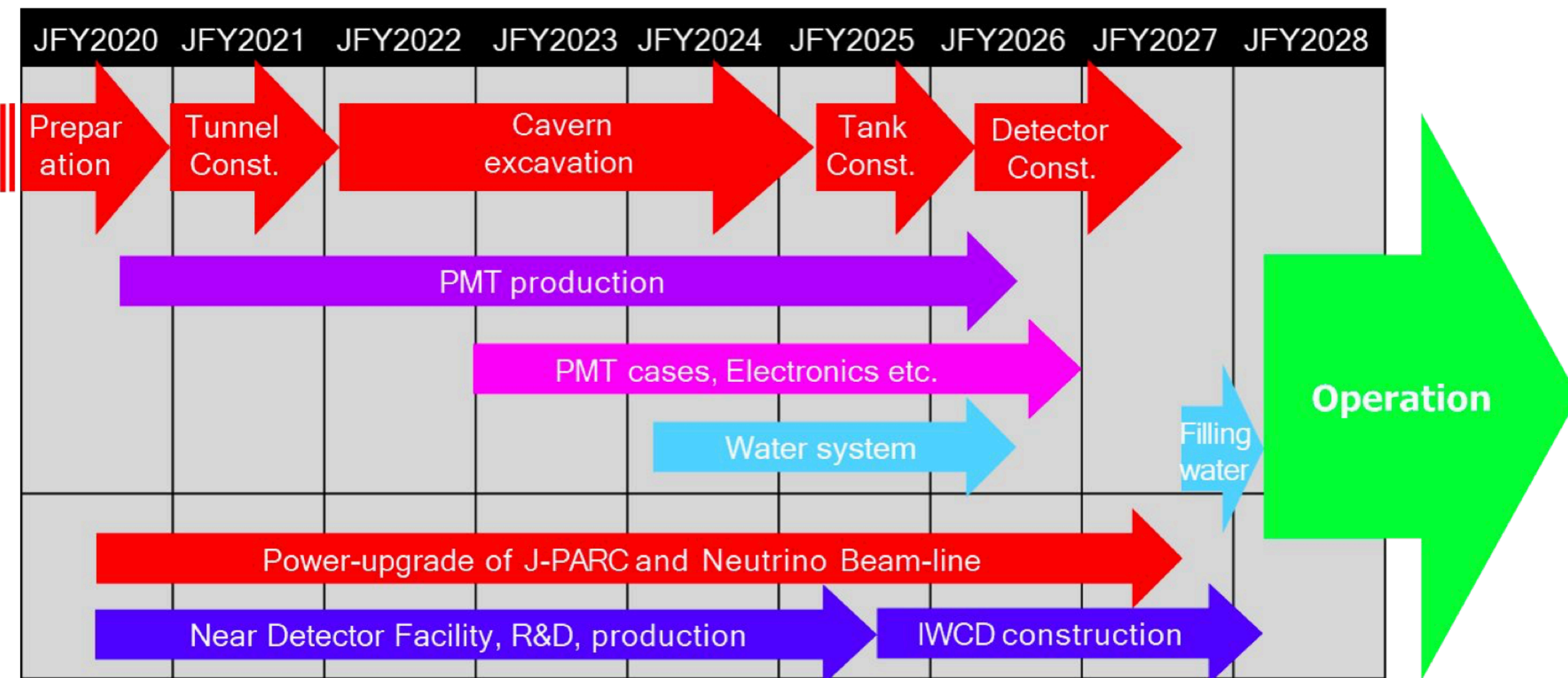

Current status

Summary

- 🧑 Lots of exciting physics results from T2K and Super-K
- 🧑 Effort is quickly ramping up toward Hyper-K construction, but analysis work also ongoing
- 🧑 Liverpool hosted NuFACT2025 last September - led by Neil



...and Balint has been through 3 cars in the last 12 months

